

BIKE-LIFT



По вопросам продаж и поддержки обращайтесь:

Алматы (7273)495-231
Архангельск (8182)63-90-72
Астрахань (8512)99-46-04
Барнаул (3852)73-04-60
Белгород (4722)40-23-64
Брянск (4832)59-03-52
Владивосток (423)249-28-31
Волгоград (844)278-03-48
Вологда (8172)26-41-59
Воронеж (473)204-51-73
Екатеринбург (343)384-55-89
Иваново (4932)77-34-06
Ижевск (3412)26-03-58
Иркутск (395)279-98-46
Россия (495)268-04-70

Казань (843)206-01-48
Калининград (4012)72-03-81
Калуга (4842)92-23-67
Кемерово (3842)65-04-62
Киров (8332)68-02-04
Краснодар (861)203-40-90
Красноярск (391)204-63-61
Курск (4712)77-13-04
Липецк (4742)52-20-81
Магнитогорск (3519)55-03-13
Москва (495)268-04-70
Мурманск (8152)59-64-93
Набережные Челны (8552)20-53-41
Нижний Новгород (831)429-08-12
Киргизия (996)312-96-26-47

Новокузнецк (3843)20-46-81
Новосибирск (383)227-86-73
Омск (3812)21-46-40
Орел (4862)44-53-42
Оренбург (3532)37-68-04
Пенза (8412)22-31-16
Пермь (342)205-81-47
Ростов-на-Дону (863)308-18-15
Рязань (4912)46-61-64
Самара (846)206-03-16
Санкт-Петербург (812)309-46-40
Саратов (845)249-38-78
Севастополь (8692)22-31-93
Симферополь (3652)67-13-56
Казахстан (7172)727-132

Смоленск (4812)29-41-54
Сочи (862)225-72-31
Ставрополь (8652)20-65-13
Сургут (3462)77-98-35
Тверь (4822)63-31-35
Томск (3822)98-41-53
Тула (4872)74-02-29
Тюмень (3452)66-21-18
Ульяновск (8422)24-23-59
Уфа (347)229-48-12
Хабаровск (4212)92-98-04
Челябинск (351)202-03-61
Череповец (8202)49-02-64
Ярославль (4852)69-52-93



Codice / Item Dimensioni/Dimensions
MF-GPPLAST-08 diam.30mm L=75mm

Confezione / Package
Pezzo Sing./Single piece



Codice / Item Dimensioni/Dimensions
MF-GPPLAST-04 diam.5mm L=40mm

Confezione / Package
box 100 pcs



Codice / Item Dimensioni/Dimensions
MF-GPPLAST-07 diam.5mm L=50mm

Altezza/Height Confezione / Package
45 mm box 100 pcs



Codice / Item Dimensioni/Dimensions
MF-GPPLAST-05 diam.5mm L=35mm

Occhiello/Eye Confezione / Package
8 mm box 100 pcs



Codice / Item Dimensioni/Dimensions
MF-GPPLAST-06 diam.5mm L=38mm

Occhiello/Eye Confezione / Package
14 mm box 100 pcs



Codice / Item Dimensioni/Dimensions
MF-GPPLAST-03 diam.5mm L=25mm

Confezione /Package
box 100 pcs



Codice / Item Dimensioni/Dimensions
MF-GPPLAST-02 diam.5mm L=55mm

Confezione /Package
box 100 pcs



Codice / Item Dimensioni/Dimensions
MF-GPPLAST-01 diam.5mm L=35mm

Confezione /Package
box 200 pcs



Codice / Item Dim./Dimens.
MF-GPMETAL01/P diam.5mm L=100mm
box 100 PCS
MF-GPMETAL02/P diam.5mm L=150mm
box 50 PCS
MF-GPMETAL03/P diam.5mm l=200mm
box 50 PCS



Codice / Item Dimensioni/Dimensions
MF-BPPUNTE-01 95x65x35mm



Codice / Item Dimensioni/Dimensions
MF-VATRASP-02 125x125x65mm



Codice / Item Dimensioni/Dimensions
MF-VATRASP-01 105x105x45mm

SET ATTREZZI PER CASSETTIERE M1-M2-CB SU PREFORMATO
 M1-M2-CB DRAWERS MODULES SET OF TOOLS



Set 142 pezzi chiavi a cricchetto
 Set 142 pcs flank sockets
 Codice / Item 214201
 Mis. / Size 1/4"-3/8"



Set 93 pz. chiavi a cricc. SAE
 Set 93 pcs SAE flank sockets
 Codice / Item 309301 v.02
 Mis. / Size 1/4"-3/8"-1/2"

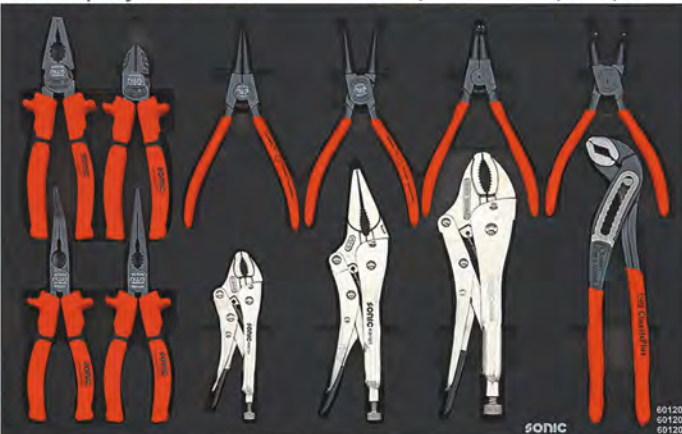

Set 12 pezzi pinze
 Set 12 pcs pliers
 Codice / Item 601207



Set 21 pz. cacc.bussola/viti esag.
 Set 21 pcs socket scr./hex grip key
 Codice / Item 602104



Set 23 pz. mart./pinze/scalp./lime
 Set 23 pcs hamm./plier/chisel/file
 Codice / Item 602302 v.4



Set 31 pz. chiavi SAE
 Set 31 pcs SAE wrenches
 Codice / Item 603101



Set 35 pz. cacciaviti/brugole
 Set 35 pcs screwdrivers
 Codice / Item 603506



Set 40 pz. chiavi
 Set 40 pcs wrenches
 Codice / Item 604002 v.2

PANNELLI PORTA ATTREZZI E ACCESSORI WALL TOOLS GRID AND ACCESSORIES

GRIGLIA PORTA ATTREZZI
WALL TOOLS GRID



Codice / Item Dimensioni/Dimensions
MF-PA2000-01 200x81x5 cm



Codice / Item Dimensioni/Dimensions
MF-PA1620-01 162x81x5 cm



Codice / Item Dimensioni/Dimensions
MF-PA1000-01 100x81x5 cm



Codice / Item Dimensioni/Dimensions
MF-BL KGP1000 100x70.5x5.5 cm
MF-BL KGP1620 162x70.5x5.5 cm
MF-BL KGP2000 200x70.5x5.5 cm

GRIGLIE PER
PENSILI
GRIDS FOR
CUPBOARDS

ARMADIO PORTA ATTREZZI CON
SERRANDA DI CHIUSURA A SERRATURA
TOOL TRAY WALL TOP CHEST WITH
PANEL AND LOCK



Codice / Item Dimensioni/Dimensions
MF-MA2000-01 200x100x20 cm

Codice / Item Dimensioni/Dimensions
MF-MA1620-01 162x100x20 cm



PENSILI
CUPBOARDS

Codice / Item Dimensioni/Dimensions
MF-BL M14 81x40x30 cm

Codice / Item Dimensioni/Dimensions
MF-BL M15 100x40x30 cm



Codice / Item Pensile ad angolo
MF-BL M17

Codice / Item Corner Cupboard
MF-BL M17

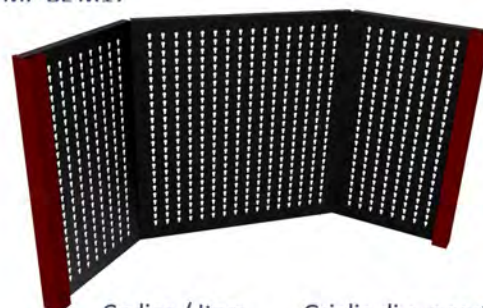

Codice / Item Griglia di supporto per
MF-BL KGP/A pensile ad angolo
Codice / Item Supporting wall grid for
MF-BL KGP/A corner cupboard

ANGOLI ED ACCESSORI MODOFLEX MODOFLEX CORNERS AND ACCESSORIES

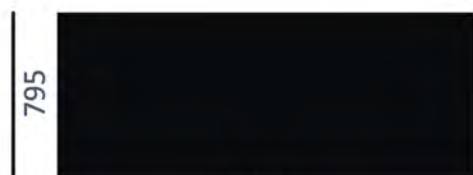

1995

Copertura gomma anti-olio
Oil-Resistant rubber cover



1610

Copertura gomma anti-olio
Oil-Resistant rubber cover



995

Copertura gomma anti-olio
Oil-Resistant rubber cover

Codice / Item	Dimens./Dimensions
MF-PG2000-01/03	1995x795x3mm
MF-PG2000-01	1995x795x6mm

Codice / Item	Dimens./Dimensions
MF-PG1620-01/03	1610x795x3mm
MF-PG1620-01	1610x795x6mm

Codice / Item	Dimens./Dimensions
MF-PG1000-01/03	995x795x3mm
MF-PG1000-01	995x795x6mm



Piano ad Angolo / *Corner Shelf*

Codice / Item	Dimensioni/Dimensions
MF-PANG-900	900x900 mm

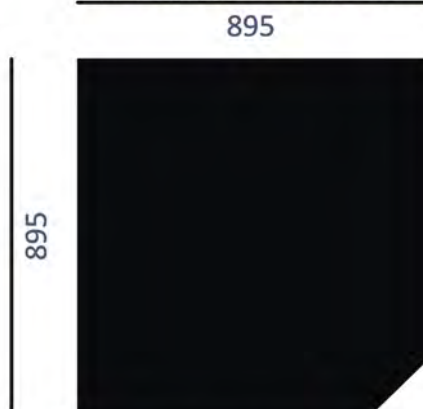

Copertura gomma anti-olio
per Piano Angolo
*Oil-Resistant rubber cover
for Corner Shelf*

Codice / Item	Dimensioni/Dimensions
MF-PGANG-01/03	895x895x3 mm
MF-PGANG-01	895x895x6 mm



Codice / Item	Dimensioni/Dimensions
MF-BL LED800	L=800 mm
MF-BL LED1000	L=1000 mm

Luci magnetiche a led bianco ghiaccio da applicare sotto ai pensili.
Magnetic ice white led lights to position under the cupboards.

ONE FITS ALL

Un sollevatore unico , progettato e realizzato per veicoli a due o quattro ruote, con capacità massima di 1000 kg. Dotato di un sistema brevettato di allargamento e di bloccaggio, si adatta facilmente e velocemente alle diverse necessità di intervento, garantendo stabilità, sicurezza e la massima accessibilità operativa su ogni lato del veicolo. Grazie all'esclusiva progettazione ed alla struttura molto robusta, è in grado di arrivare ad una altezza massima di 130 cm garantendo sempre una perfetta stabilità e la massima sicurezza durante tutta la fase di intervento. Un solo sollevatore consente di intervenire su diverse tipologie di veicoli rendendo quindi l'officina polifunzionale e tecnicamente completa. E' azionato da una centralina elettro-idraulica silenziosa, potente e veloce, che garantisce un sollevamento costante e privo di vibrazioni, sia nella fase di salita che di discesa. Il WIDER viene fornito con sicurezza meccanica a 11 posizioni, sgancio pneumatico della sicura, rampe di salita e ferma ruote anteriori.



A unique bike-lift, designed and manufactured for two or four-wheeled vehicles, with a maximum load capacity of 1000 kg. It is equipped with a patented widening and locking system and adapts quickly and easily to all operating needs, ensuring stability, safety and accessibility to all sides of the vehicle. Thanks to its unique design and extremely robust structure it can reach a maximum height of 130 cm, always providing perfect stability and the utmost safety during each phase of the operation. One lift alone that allows to work on various types of vehicles, thus making the workshop multi-functional and technically complete. The lift is operated by a silent, powerful and fast electro-hydraulic unit, ensuring a constant lifting and descent movement without vibrations. The WIDER lift is equipped with a mechanical safety device with 11 different locking positions that is released pneumatically, two run-up ramps and two front wheel end stop plates.

WIDER 1000

Patent N° 11183040.2

Bike-Lift®
EUROPE

WD-003 | Pompa Elettro Idraulica / *Electro-hydraulic Pump*



Portata / *Max load capacity*

Altezza Max / *Max Height*

Altezza Min. / *Min. Height*

Posizioni Sicura / *Safety Position*

Lunghezza / *Length*

Dim. Piano Sollevamento Chiuso / *Tabletop size when closed*

Dim. Piano Sollevamento Aperto / *Tabletop size when open*

Dimensioni Binario / *Ground Rail size*

Dimensioni Rampa di Salita / *Run-up Ramp size*

Ingombro Totale Sollevatore / *Overall Dimensions*

Peso / *Weight*

1000 Kg / 2204 Lbs

130 cm / 4.2 Ft

20 cm / 7.8 Inch.

11

230 cm / 7.5 Ft

84x230 cm / 2.7x7.5 Ft

150x230 cm / 4.9x7.5 Ft

40x150 cm / 1.3x4.9 Ft

82x40.5 cm / 2.7x1.3 Ft

240x100 cm / 7.8x3.3 Ft

300 Kg / 661 Lbs

Centralina Elettro-Idraulica
Electro-Hydraulic Power Unit

Potenza / *Power*

Europa / *Europe*

Giappone / *Japan*

America / *USA*

1,1 Kw

230 Volts - 50 Hz

200 Volts - 50/60 Hz

110 Volts - 60 Hz

Torretta di controllo

Control Panel

Di serie / *Included*

DOTAZIONE DI SERIE / *STD EQUIP.*

Rampe / *Run-up Ramps* 2 pcs

Imballo Std. Cassa Legno

Std. Packing wood box 235x102x60cm

Peso Imballo/Packing Weight 320 kg

Fermaruota / *Wheel stop* 2 pcs

Torretta / *Tower Control* 1 pc



A MEAN MACHINE

IL TWIN ARMS E' IL SOLLEVATORE per moto più completo e tecnologico sul mercato. La struttura classica è stata completata con un sistema di sollevamento idraulico a due bracci sincronizzati che, una volta assicurate le pedane o l'inserimento del perno passante, consente di sollevare dal piano di lavoro una o addirittura entrambe le ruote.

LA VERSATILITA' d'uso e la semplicità di gestione del veicolo fanno del Twin Arms un sollevatore unico nel suo genere, simbolo di alta tecnologia e design funzionale, particolarmente apprezzato dalle officine che effettuano molti cambi gomme o interventi sulle forcelle e ammortizzatori. La massima capacità di carico del sollevatore è di 500 Kg. Raggiunge l'elevazione massima di 120 cm ed i due bracci si sollevano a loro volta fino a 60 cm. Viene fornito con una cinghia automatica di sicurezza in dotazione.

THE TWIN ARMS BIKE LIFT is the most complete and technologically advanced lift on the market. The classical scissor lift structure has been integrated by an hydraulic lifting system of two synchronized arms that allows to detach one or even both wheels from the lifting platform once the footpegs are safely secured to the arms or the motorbike is taken from the central swing arm by means of an adapter sliding through it. Its VERSATILE use and a simple vehicle management make the Twin Arms a unique lift, a symbol of high technology and functional design, particularly appreciated by workshops that perform many tyre changes or work on forks and shock absorbers. The maximum load capacity of the lift is 500 kg. It reaches the maximum height of 120 cm and the two arms raise up to another 60 cm. It is supplied with an automatic safety tie down strap included.



MAX Twin Arms 500

Bike-Lift®
EUROPE



MTA516-002	Pompa ad Aria / <i>Air Pump</i>
MTA516-003	Pompa Elettro-Idraulica / <i>Electro-Hydraulic Pump</i>
MTA516-004/R	Pompa Elettro-Idraulica con Comando Remoto / <i>Electro-Hydraulic Pump w/Remote</i>

Portata / *Max load capacity*

Altezza Max / *Max Height*

Altezza Min. / *Min. Height*

Posizioni Sicura / *Safety Position*

Dimensione Piano Sollevamento / *Tabletop size*

Dimensioni Rampa di Salita / *Run-up Ramp size*

Ingombro Totale Sollevatore / *Overall Dimensions*

Portata Max bracci idraulici / *Arms Max. load Capacity*

Altezza Max bracci idraulici / *Max. Height Arms*

Altezza Min. bracci idraulici / *Min. Height Arms*

Peso / *Weight*

500 Kg / 1100 Lbs

120 cm / 4 Ft

20 cm / 7.8 Inch.

8

210x75 cm / 6.8x2.4 Ft

82x51 cm / 2.7x1.7 Ft

220x99 cm / 7.2x3.2 Ft

350 kg / 771 Lbs

60 cm / 1.97 Ft

20 cm / 7.8 Inch

280 Kg / 617 Lbs



Centralina Elettro-Idraulica Electro-Hydraulic Power Unit

Potenza / <i>Power</i>	1,1 Kw
Europa / <i>Europe</i>	230 Volts - 50 Hz
Giappone / <i>Japan</i>	200 Volts - 50/60 Hz
America / <i>USA</i>	110 Volts - 60 Hz

DOTAZIONE DI SERIE / *STD EQUIP.*

Rampe / <i>Run-up Ramps</i>	1 pc
Imballo Std. / <i>Std. Packing</i>	
Scat. Cartone con pallet Legno / <i>Cardboard w/wooden crate</i>	
Morsa W-36s / <i>W-36s Wheel Clamp</i>	1 pcs
Supporti Pedane / <i>Foot-peg supports</i>	2 pcs
Cinghiette Pedane / <i>Short Tie-down</i>	4 pcs
Cinghia Automatica / <i>Automatic Tie-down</i>	1 pc

BUILT TO LAST

L'ABSOLUTE 756 SPLIT è stato sviluppato per essere una macchina infaticabile ed affidabile intervento dopo intervento, anno dopo anno. Originariamente sviluppato per operare con moto di dimensioni considerevoli si è dimostrato nel corso degli anni molto versatile anche su moto sportive o Street bikes. Capace di sollevare 750 kg in completa sicurezza e bilanciamento fino ad una altezza di 130 cm. Nella versione SPLIT la parte anteriore può essere sganciata per avere una maggiore rapidità del cambio gomma o di un intervento sulle forcelle.

THE ABSOLUTE 756 WAS DEVELOPED to be a tireless and reliable machine, intervention after intervention, year after year. Originally designed to operate on larger motorcycles, it has proved to be very versatile over the years, even on sport bikes or street bike. It can lift 750 kg in complete safety and balancing up to an height of 130 cm. In the SPLIT version the front part can be unhooked and dropped for faster tire changeover or service on the forks.



ABSOLUTE 756 Split

Patent Design No. 2546986-0001

Bike-Lift®
EUROPE



AS756-002	Pompa ad Aria / Air Pump
AS756-003	Pompa Elettro-Idraulica / Electro-Hydraulic Pump
AS756-004/R	Pompa Elettro-Idraulica con Comando Remoto / Electro-Hydraulic Pump w/Remote

Portata / Max load capacity

Altezza Max / Max Height

Altezza Min. / Min. Height

Posizioni Sicura / Safety Position

Dimensione Piano Sollevamento / Tabletop size

Dimensioni Rampa di Salita / Run-up Ramp size

Ingombro Totale Sollevatore / Overall Dimensions

Ingombro Tot. Piano di Sollev. / Tabletop overall Dimensions

Dimensioni Ali Laterali / Side Wings Dimensions

Dimensione Sportello Gate / Sliding panel Dimensions

Dimensione Sportello Split / Drop panel Dimensions

Peso / Weight

750 Kg / 1650 Lbs

130 cm / 4.3 Ft

20 cm / 7.8 Inch.

8

220x75 cm / 7x2.5 Ft

82x51 cm / 2.7x1.7 Ft

230x99 cm / 7.5x3 Ft

220x92 cm / 7x3 Ft

161x8.5 cm / 5 Ft x 3.3 Inch

60x36 cm / 23x14 Inch

75x44.5 cm / 29x17 Inch

265 Kg / 584 Lbs



Centralina Elettro-Idraulica Electro-Hydraulic Power Unit

Potenza / Power	1,1 Kw
Europa / Europe	230 Volts - 50 Hz
Giappone / Japan	200 Volts - 50/60 Hz
America / USA	110 Volts - 60 Hz

Pompa ad Aria / Air Pump

Pressione Aria / Air Pressure	7-10 Bar
Consumo Aria / Air Consumption	300L/Min

DOTAZIONE DI SERIE / STD EQUIP.

Rampe / Run-up Ramps	1 pc
Imballo Std. / Std. Packing	
Scat. Cartone con pallet Legno/ Cardboard w/wooden crate	
Fermaruota / Wheel stop	1 pc
PZA Placca Protez./PZA Chequerplate	1 pc
Ali Laterali / Side Wings	2 pcs



PZA

(BIG) CRUISER FRIENDLY

LA VERSIONE ABSOLUTE GATE, LA PIU' utilizzata nelle officine a forte incidenza di grandi Cruiser e moto Custom. Il modello che più rappresenta l'idea di stabilità, sicurezza e durata nel tempo che da sempre sono i punti fermi della nostra filosofia costruttiva, ed un punto di riferimento per tutto il mondo del sollevamento moto.

THE ABSOLUTE 756 GATE VERSION is mostly used in workshops working on large Cruisers or Custom bikes. This is the lift model that mostly accounts for stability, safety and durability in time, which are the strongholds of our manufacturing philosophy, and is a worldwide point of reference for the entire motorcycle lifting sector.



ABSOLUTE 756 Gate

Patent Design No. 2546986-0001



AG756-002	Pompa ad Aria / Air Pump
AG756-003	Pompa Elettro-Idraulica / Electro-Hydraulic Pump
AG756-004/R	Pompa Elettro-Idraulica con Comando Remoto / Electro-Hydraulic Pump w/Remote

Portata / Max load capacity	750 Kg / 1650 Lbs
Altezza Max / Max Height	130 cm / 4.3 Ft
Altezza Min. / Min. Height	20 cm / 7.8 Inch.
Posizioni Sicura / Safety Position	8
Dimensione Piano Sollevamento / Tabletop size	220x75 cm / 7x2.5 Ft
Dimensioni Rampa di Salita / Run-up Ramp size	82x51 cm / 2.7x1.7 Ft
Ingombro Totale Sollevatore / Overall Dimensions	230x99 cm / 7,5x3.2 Ft
Ingombro Tot. Piano di Sollev. / Tabletop overall Dimensions	220x92 cm / 7x3 Ft
Dimensioni Ali Lateralali / Side Wings Dimensions	212x8.5 cm / 5 Ft x 3.3 Inch
Dimensione Sportello Gate / Sliding panel Dimensions	60x36 cm / 23x14 Inch
Peso / Weight	260 Kg / 573 Lbs



Centralina Elettro-Idraulica Electro-Hydraulic Power Unit

Potenza / Power	1,1 Kw
Europa / Europe	230 Volts - 50 Hz
Giappone / Japan	200 Volts - 50/60 Hz
America / USA	110 Volts - 60 Hz

Pompa ad Aria / Air Pump

Pressione Aria / Air Pressure	7-10 Bar
Consumo Aria / Air Consumption	300L/Min

DOTAZIONE DI SERIE / STD EQUIP.

Rampe / Run-up Ramps	1 pc
Imballo Std. / Std. Packing	
Scat. Cartone con pallet Legno/ Cardboard w/wooden crate	
Feraruota / Wheel stop	1 pc
PZA Placca Protez. / PZA Chequerplate	1 pc
Ali Lateralali / Side Wings	2 pcs



PZA

TRIKE THIS

I TRIKE SONO SEMPRE PIU' PRESENTI nel panorama motociclistico internazionale quindi non poteva mancare nella nostra gamma questa versione specifica. Considerando la struttura di un Trike ed il suo peso non potevamo che scegliere il modello ABSOLUTE come base, su cui sono state applicate due robustissime ali per le ruote posteriori o anteriori del Trike. La stabilità è certamente la dote principale di questo sollevatore, che sicuramente si pone come punto di riferimento sul mercato.

TRIKES ARE MORE AND MORE PRESENT in the international motorcycle scene, so we couldn't miss this specific lift version in our range . Considering the structure of a Trike and its weight we couldn't do anything but choose the ABSOLUTE model as a base, on which two very sturdy side extension wings were applied for the front wheels of the Trike. Stability is the main feature of this lift, which certainly stands as a benchmark on the market.



ABSOLUTE 756 Spider

Patent Design No. 2546986-0001

Bike-Lift®
EUROPE



SP756-003
SP756-004/R

Pompa Elettro-Idraulica / *Electro-Hydraulic Pump*

Pompa Elettro-Idraulica con Comando Remoto / *Electro-Hydraulic Pump w/Remote*

Portata / *Max load capacity*

Altezza Max / *Max Height*

Altezza Min. / *Min. Height*

Posizioni Sicura / *Safety Position*

Dimensione Piano Sollevamento / *Tabletop size*

Dimens. Rampa di Salita(centrale) / *Run-up Ramp size (central)*

Ingombro Totale Sollevatore / *Overall Dimensions*

Dimens. rampe di allargamento/ *Run-up side tool wings*

Peso / *Weight*

750 Kg / 1650 Lbs

130 cm / 4.3 Ft

20 cm / 7.8 Inch.

8

220x75 cm / 7x2.5 Ft

82x51 cm / 2.7x1.7 Ft

230x160 cm / 7.5x5.2 Ft

23.5x82 cm / 9.3x2.7 Ft

290 Kg / 638 Lbs



* tappeto optional / *cover mat optional*

Centralina Elettro-Idraulica
Electro-Hydraulic Power Unit

Potenza / *Power*
Europa / *Europe*
Giappone / *Japan*
America / *USA*

1,1 Kw
230 Volts - 50 Hz
200 Volts - 50/60 Hz
110 Volts - 60 Hz

DOTAZIONE DI SERIE / STD EQUIP.

Rampe / <i>Run-up Ramps</i>	3 pc
Imballo Std. / <i>Std. Packing</i>	
Scat. Cartone con pallet Legno/ <i>Cardboard w/wooden crate</i>	
Feraruota / <i>Wheel stop</i>	3 pc
PZA Placca Protez, / <i>PZA Chequerplate</i>	1 pc
Ali Allargamento/ <i>Extension Wings</i>	2 pcs



PZA

SLIDE AND SAVE (SPACE)

POTER SOLLEVARE UNA MOTO fino a 130cm di altezza non è certamente indispensabile, ma sicuramente è di grande aiuto in termini di efficacia e comfort durante l'intervento sul veicolo. Il MASTER 504 rappresenta la miglior soluzione per le officine che hanno una clientela varia e quindi una tipologia di intervento che va dallo scooter alle grandi sportive o Sport Tourer. E' dotato di un ampio Gate a scomparsa e, unico modello nella nostra gamma, di una rampa di salita integrata e scorrevole, che rientra automaticamente all'interno del sollevatore quando viene alzato.

LIFTING A MOTORCYCLE up to 130 cm height is certainly not essential, but it surely helps greatly in terms of effectiveness and comfort during vehicle servicing. The MASTER 504 lift represents the best solution for workshop that have a varied customer base and need therefore to intervene on vehicles ranging from mopeds to larger sport or street Touring bikes. It is equipped with a large sliding panel and, only model in our range, with an integrated and sliding run-up ramp, which automatically retracts into the chassis when it is raised.



MASTER 504

Bike-Lift®
EUROPE



MA504-002	Pompa ad Aria / Air Pump
MA504-003	Pompa Elettro-Idraulica / <i>Electro-Hydraulic Pump</i>
MA504-004/R	Pompa Elettro-Idraulica con Comando Remoto / <i>Electro-Hydraulic Pump w/Remote</i>

Portata / *Max load capacity*

Altezza Max / *Max Height*

Altezza Min. / *Min. Height*

Posizioni Sicura / *Safety Position*

Dimensione Piano Sollevamento / *Tabletop size*

Dimens. Rampa di Salita mobile / *Sliding Run-up Ramp size*

Ingombro Totale Sollevatore / *Overall Dimensions*

Dimens. Ali Laterali / *Side Wings Dimensions*

Ingombro Totale piano sollev. / *Tabletop overall dimensions*

Dimensioni Sportello Gate / *Drop GATE panel dimensions*

Peso / *Weight*

500 Kg / 1102 Lbs

130 cm / 4.3 Ft

20 cm / 7.8 Inch.

8

210x75 cm / 6.9x2.5 Ft

70x50 cm / 2.30x1.60 Ft

220x99 cm / 7.2x3.2 Ft

210x8.5 cm / 6.9 Ft x 3.3 Inch

210x92 cm / 6.9x3 Ft

60x36 cm / 1.95x1.20 Ft

250 Kg / 551 Lbs



Centralina Elettro-Idraulica Electro-Hydraulic Power Unit

Potenza / <i>Power</i>	1,1 Kw
Europa / <i>Europe</i>	230 Volts - 50 Hz
Giappone / <i>Japan</i>	200 Volts - 50/60 Hz
America / <i>USA</i>	110 Volts - 60 Hz

Pompa ad Aria / Air Pump

Pressione Aria / <i>Air Pressure</i>	7-10 Bar
Consumo Aria / <i>Air Consumption</i>	300L/Min

DOTAZIONE DI SERIE / *STD EQUIP.*

Rampe / <i>Run-up Ramps</i>	1 pc
Imballo Std. / <i>Std. Packing</i>	
Scat. Cartone con pallet Legno/ <i>Cardboard w/wooden crate</i>	
Fermaruota / <i>Wheel stop</i>	1 pc
Lam. Protezione/Chequerplate	1 pc
Ali laterali / <i>Side wings</i>	1 pc



PZA

LOW & HIGH EFFICIENCY

IL SOLLEVATORE A MINIMA ALTEZZA da terra è, per la nostra gamma, una assoluta novità. Abbiamo atteso e studiato tutte le problematiche che un progetto come questo presenta, a partire dalla stabilità e dalla robustezza. Lo sforzo generato sulla struttura è notevole e quindi abbiamo preferito avere la certezza di una macchina in linea con tutte le altre che hanno reso famoso nel mondo il marchio BIKE LIFT piuttosto che farsi condurre dalla fretta e lanciare sul mercato un sollevatore qualunque. Da questa idea di tecnologia e performances senza compromessi nasce il CUSTOM 500, con una altezza minima di 9 cm ed una massima di 110 cm, il partner ideale per le grandi Harley e le moto customizzate. Basso ma con una ALTISSIMA EFFICIENZA operativa.

HAVING A LIFT AT MINIMUM HEIGHT from the ground is, for our range, an absolute novelty. We have awaited and studied all the problems that a project like this presents, starting from stability and robustness. The lifting effort generated on the lift structure is enormous and therefore we preferred to be sure of manufacturing a lift in line with all the other that have made BIKE-LIFT brand famous in the world, rather than being hurried and launch anything on the market. From this idea of technology and uncompromising performance comes CUSTOM 500, with a minimum height of 9 cm and a maximum height of 110 cm, this lift is the ideal partner for large Harleys and customized motorcycles. Low but with VERY HIGH operating efficiency,

La torretta di controllo può essere sostituita con il modulo comandi M16 inserito nel banco di lavoro.

The control tower can be replaced by a command module M16 fitted into the workbench.



CUSTOM 500

Bike-Lift®
EUROPE



CU500-003

Pompa Elettro-Idraulica / *Electro-Hydraulic Pump*

Portata / *Max load capacity*

Altezza Max / *Max Height*

Altezza Min. / *Min. Height*

Dimensione Piano Sollevamento / *Tabletop size*

Dimens. Rampa di Salita mobile / *Sliding Run-up Ramp size*

Ingombro Totale Sollevatore / *Overall Dimensions*

Dimens. Ali Laterali / *Side Wings Dimensions*

Ingombro Totale piano sollev. / *Tabletop overall dimensions*

Dimensioni Sportello Gate / *Drop GATE panel dimensions*

Peso / *Weight*

500 Kg / 1102 Lbs

110 cm / 3.6 Ft

9 cm / 3.5 Inch.

220x80 cm / 7.2x2.6 Ft

51.6x24 cm / 1.69 Ft x 9.4 Inch

220x98 cm / 7.2x3.2 Ft

220x8.5 cm / 7.2 Ft x 3.3 Inch

220x98 cm / 7.2x3.2 Ft

60x28 cm / 1.95 Ft x 11 Inch

285 Kg / 628 Lbs

Torretta Controllo / *Control Tower*
Inclusa / *Included*

Centralina Elettro-Idraulica
Electro-Hydraulic Power Unit



Rampa automatica / *Automatic Ramp*

Potenza / <i>Power</i>	1,1 Kw
Europa / <i>Europe</i>	230 Volts - 50 Hz
Giappone / <i>Japan</i>	200 Volts - 50/60 Hz
America / <i>USA</i>	110 Volts - 60 Hz

DOTAZIONE DI SERIE / *STD EQUIP.*

Rampa / <i>Run-up Ramp</i>	1 pc
Imballo Std. / <i>Std. Packing</i>	
Scat. Cartone con pallet Legno/ <i>Cardboard w/wooden crate</i>	
Fermaruota / <i>Wheel stop</i>	1 pc
PZA Placca Prot./ <i>PZA Chequerplate</i>	1 pc
Ali laterali / <i>Side Wings</i>	2 pcs



PZA

NORMALLY EXTRAORDINARY

IL PIU' VENDUTO DA SEMPRE. La migliore espressione della tecnologia e del design, semplice ma con performances straordinarie. Dal suo lancio sul mercato 15 anni fa sono state apportate tante piccole miglioni che lo hanno reso oggi la macchina più completa e versatile per ogni tipo di officina. Disponibile con tutte le opzioni di motorizzazione, dalla pompa a pedale alla centralina elettro-idraulica con comando remoto. Viene utilizzato anche come base per il montaggio delle ali di allargamento PSW516, che permettono al sollevatore di poter operare con veicoli a quattro ruote.

THE MOST SOLD LIFT EVER. The best expression of technology and design, simple but with extraordinary performances. Many small improvements have been made since its launch on the market 15 years ago, making this lift the most complete and versatile one for any kind of workshop. Available in all operating models, ranging from foot-pump to remotely controlled electro-hydraulic pump unit. This lift is also used as base to install the PSW516 side extension wings, allowing it to be used for 4-wheeled vehicles as well.



MAX GATE

516



MG516-001	Pompa a Pedale / <i>Foot Pump</i>
MG516-002	Pompa ad Aria / <i>Air Pump</i>
MG516-003	Pompa Elettro-Idraulica / <i>Electro-Hydraulic Pump</i>
MG516-004/R	Pompa Elettro-Idraulica con Comando Remoto / <i>Electro-Hydraulic Pump w/Remote</i>

Portata / *Max load capacity*

Altezza Max / *Max Height*

Altezza Min. / *Min. Height*

Posizioni Sicura / *Safety Position*

Dimensione Piano Sollevamento / *Tabletop size*

Dimens. Rampa di Salita / *Run-up Ramp size*

Ingombro Totale Sollevatore / *Overall Dimensions*

Dimens. Ali Laterali / *Side Wings Dimensions*

Ingombro Totale piano sollev. / *Tabletop overall dimensions*

Dimensioni Sportello Gate / *Sliding GATE panel dimensions*

Peso / *Weight*

500 Kg / 1102 Lbs

120 cm / 4 Ft

20 cm / 7.8 Inch.

8

210x75 cm / 6.9x2.5 Ft

82x51 cm / 2.7x1.6 Ft

220x99 cm / 7,3x3.3 Ft

210x12 cm / 6.8 Ft x 4.7 Inch

210x99 cm / 6.8x3.3 Ft

60x36 cm / 1.95x1.20 Inch

235 Kg / 518 Lbs

Centralina Elettro-Idraulica
Electro-Hydraulic Power Unit

Potenza / <i>Power</i>	1,1 Kw
Europa / <i>Europe</i>	230 Volts - 50 Hz
Giappone / <i>Japan</i>	200 Volts - 50/60 Hz
America / <i>USA</i>	110 Volts - 60 Hz

Pompa ad Aria / *Air Pump*

Pressione Aria / <i>Air Pressure</i>	7-10 Bar
Consumo Aria / <i>Air Consumption</i>	300L/Min

DOTAZIONE DI SERIE / *STD EQUIP.*

Rampe / <i>Run-up Ramps</i>	1 pc
Imballo Std. / <i>Std. Packing</i>	
Scat. Cartone con pallet Legno/ <i>Cardboard w/wooden crate</i>	
Fermaruota / <i>Wheel stop</i>	1 pc
Ali Laterali / <i>Side Wings</i>	2 pcs
PZA Placca Protez./ <i>PZA Chequerplate</i>	1 pc



PZA



MAX PERFORMANCE

VERSIONE CON PIANO DI sollevamento unico, senza lo sportello Gate. Viene utilizzato come base per il modello Twin Arms, grazie alla eccezionale stabilità e fluidità del movimento. Questo modello è la base ideale per il montaggio delle ali di allargamento PSW516 che trasformano il sollevatore moto in sollevatore per veicoli a 4 ruote, dove l'utilizzo del pannello Gate non è indispensabile.

This version has a FULL FLAT TABLE TOP, without the Gate panel. It is used as a base for the TWIN ARMS lift, thanks to its great stability and fluidity of movement. It is also the ideal base base to install the PSW156 side extension wings, which transforms a standard motorcycle lift in a 4-wheeled vehicle lift, where the use of the Gate panel is not strictly necessary.



* Ali di allargamento non incluse /
Extension wings not included

MAX 516



M516-001	Pompa a Pedale / <i>Foot Pump</i>
M516-002	Pompa ad Aria / <i>Air Pump</i>
M516-003	Pompa Elettro-Idraulica / <i>Electro-Hydraulic Pump</i>
M516-004/R	Pompa Elettro-Idraulica con Comando Remoto / <i>Electro-Hydraulic Pump w/Remote</i>

Portata / *Max load capacity*

Altezza Max / *Max Height*

Altezza Min. / *Min. Height*

Posizioni Sicura / *Safety Position*

Dimensione Piano Sollevamento / *Tabletop size*

Dimens. Rampa di Salita / *Run-up Ramp size*

Ingombro Totale Sollevatore / *Overall Dimensions*

Dimens. Ali Laterali / *Side Wings Dimensions*

Ingombro Totale piano sollev. / *Tabletop overall dimensions*

Peso / *Weight*

500 Kg / 1102 Lbs

120 cm / 4 Ft

20 cm / 7.8 Inch.

8

210x75 cm / 6.9x2.5 Ft

82x51 cm / 2.7x1.6 Ft

220x99 cm / 7,3x3.3 Ft

210x12 cm / 6.8 Ft x 4.7 Inch

210x99 cm / 6.8x3.3 Ft

235 Kg / 518 Lbs



Centralina Elettro-Idraulica
Electro-Hydraulic Power Unit

Potenza / <i>Power</i>	1,1 Kw
Europa / <i>Europe</i>	230 Volts - 50 Hz
Giappone / <i>Japan</i>	200 Volts - 50/60 Hz
America / <i>USA</i>	110 Volts - 60 Hz

Pompa ad Aria / *Air Pump*

Pressione Aria / <i>Air Pressure</i>	7-10 Bar
Consumo Aria / <i>Air Consumption</i>	300L/Min

DOTAZIONE DI SERIE / *STD EQUIP.*

Rampa / <i>Run-up Ramp</i>	1 pc
Imballo Std. / <i>Std. Packing</i>	
Scat. Cartone con pallet Legno/ <i>Cardboard w/wooden crate</i>	
Fermaruota / <i>Wheel stop</i>	1 pc
Ali Laterali / <i>Side Wings</i>	2 pcs
PZA Placca Protez./ <i>PZA Chequerplate</i>	1 pc



PZA

SLIM FOR BIGGER SPACE

IL MODELLO SPORT GATE 500 è stato progettato per rispondere a due esigenze specifiche : spazio limitato e necessità di operare nel modo più ergonomico possibile sulle moto sportive e scooters di grossa cilindrata. Il piano di lavoro, largo solo 60 cm, consente al meccanico di poter essere molto vicino alla moto e quindi di poter lavorare nella massima comodità, efficienza e sicurezza. E' fornito di un pannello GATE a caduta per lo smontaggio della ruota posteriore.

The SPORT GATE 500 LIFT has been designed to meet two specific requirements: limited space and necessity to operate as ergonomically as possible on sport bikes and large displacements mopeds. The table top is only 60 cm wide and allows the operator to work very close to the bike and with the utmost level easiness, efficiency and safety. It is equipped with a dropping GATE panel for an easy disassembly of the rear wheel.



SPORT GATE

500/17

Bike-Lift®
EUROPE™



SG-001 500/17	Pompa a Pedale / <i>Foot Pump</i>
SG-002 500/17	Pompa ad Aria / <i>Air Pump</i>
SG-003 500/17	Pompa Elettro-Idraulica / <i>Electro-Hydraulic Pump</i>
SG-004/R 500/17	Pompa Elettro-Idraulica con Comando Remoto / <i>Electro-Hydraulic Pump w/Remote</i>

Portata / *Max load capacity*

Altezza Max / *Max Height*

Altezza Min. / *Min. Height*

Posizioni Sicura / *Safety Position*

Dimensione Piano Sollevamento / *Tabletop size*

Dimens. Rampa di Salita / *Run-up Ramp size*

Ingombro Totale Sollevatore / *Overall Dimensions*

Dimens. Ali Laterali / *Side Wings Dimensions*

Ingombro Totale piano sollev. / *Tabletop overall dimensions*

Dimensioni sportello Gate / *Sliding Gate panel dimensions*

Peso / *Weight*

500 Kg / 1102 Lbs

120 cm / 4 Ft

20 cm / 7.8 Inch.

8

210x60 cm / 6.8x2 Ft

62x44.5 cm / 2x1.4 Ft

220x84 cm / 7,2x2.7 Ft

210x12 cm / 6.8 Ft x 4.7 Inch

210x84 cm / 6.8x2.7 Ft

60x36 cm / 1.95x1.2 Ft

200 Kg / 441 Lbs



Centralina Elettro-Idraulica
Electro-Hydraulic Power Unit

Potenza / <i>Power</i>	1,1 Kw
Europa / <i>Europe</i>	230 Volts - 50 Hz
Giappone / <i>Japan</i>	200 Volts - 50/60 Hz
America / <i>USA</i>	110 Volts - 60 Hz

Pompa ad Aria / *Air Pump*

Pressione Aria / <i>Air Pressure</i>	7-10 Bar
Consumo Aria / <i>Air Consumption</i>	300L/Min

DOTAZIONE DI SERIE / *STD EQUIP.*

Rampa / <i>Run-up Ramp</i>	1 pc
Imballo Std. / <i>Std. Packing</i>	
Scat. Cartone con pallet Legno/ <i>Cardboard w/wooden crate</i>	
Fermaruota / <i>Wheel stop</i>	1 pc
Ali Laterali / <i>Side Wings</i>	2 pcs
PZA Placca Protez./ <i>PZA Chequerplate</i>	1 pc



PZA

BASIC EXCELLENCE

IL RACING 350 RAPPRESENTA la soluzione base tra tutti i modelli della nostra gamma, offrendo gli stessi standard di qualità tecniche dei modelli con maggiore capacità di sollevamento ad un prezzo più contenuto. Grazie alle dimensioni contenute è consigliato per le officine che intervengono principalmente su moto sportive, off-road e scooters, oltre che essere spesso scelto dai bikers che si dedicano al fai da te o dai restauratori di moto d'epoca.

The RACING 350 LIFT represents the basic solution among the entire range of our lifts, ensuring the same technical and quality standards of models with a higher load capacity, but at a lower price. Thanks to its smaller sizes it is recommended for workshops working mainly on sport bikes, off-road and mopeds, but it is also chosen by individual bikers that performs DIY repair or by vintage restorers



RACING

350/17

Bike-Lift®
EUROPE



R-001 350/17	Pompa a Pedale / <i>Foot Pump</i>
R-002 350/17	Pompa ad Aria / <i>Air Pump</i>
R-003 350/17	Pompa Elettro-Idraulica / <i>Electro-Hydraulic Pump</i>
R-004/R 350/17	Pompa Elettro-Idraulica con Comando Remoto / <i>Electro-Hydraulic Pump w/Remote</i>

Portata / *Max load capacity*

Altezza Max / *Max Height*

Altezza Min. / *Min. Height*

Posizioni Sicura / *Safety Position*

Dimensione Piano Sollevamento / *Tabletop size*

Dimens. Rampa di Salita / *Run-up Ramp size*

Ingombro Totale Sollevatore / *Overall Dimensions*

Dimens. Ali Laterali / *Side Wings Dimensions*

Ingombro Totale piano sollev. / *Tabletop overall dimensions*

Peso / *Weight*

350 Kg / 771 Lbs

120 cm / 4 Ft

20 cm / 7.8 Inch.

8

200x60 cm / 6.5x2 Ft

62x44.5 cm / 2x1.4 Ft

210x84 cm / 6.8x2.7 Ft

200x12 cm / 6.5 Ft x 4.7 Inch

200x84 cm / 6.5x2.7 Ft

180 Kg / 397 Lbs



Centralina Elettro-Idraulica
Electro-Hydraulic Power Unit

Potenza / <i>Power</i>	1,1 Kw
Europa / <i>Europe</i>	230 Volts - 50 Hz
Giappone / <i>Japan</i>	200 Volts - 50/60 Hz
America / <i>USA</i>	110 Volts - 60 Hz

Pompa ad Aria / *Air Pump*

Pressione Aria / <i>Air Pressure</i>	7-10 Bar
Consumo Aria / <i>Air Consumption</i>	300L/Min

DOTAZIONE DI SERIE / *STD EQUIP.*

Rampa / <i>Run-up Ramp</i>	1 pc
Imballo Std. / <i>Std. Packing</i>	
Scat. Cartone con pallet Legno/ <i>Cardboard w/wooden crate</i>	
Fermaruota / <i>Wheel stop</i>	1 pc
Ali Laterali / <i>Side Wings</i>	2 pcs

WIDER IS BETTER

QUESTO SOLLEVATORE, INIZIALMENTE progettato per il sollevamento di trattorini tosaerba, grazie alle sue caratteristiche, ha trovato nel corso degli anni diverse applicazioni sia in campo industriale che privato. Ha un piano di sollevamento di 120 cm di larghezza e 215 di lunghezza ed una capacità di sollevamento di 1000 kg a 100 cm di altezza. E' fornito di serie con doppia rampa di salita.

This lift, initially designed to lift riding lawn mowers, thanks to its characteristics has found over the years various applications both in the industrial and private sectors.
It has a 120 cm wide and 215 long lifting table and a lifting capacity of 1000 kg at 100 cm height. It is supplied as standard with a double run-up ramp and two wheel stoppers.



GARDEN 1000

Bike-Lift®
EUROPE



G-003/10
G-004/10R

Pompa Elettro-Idraulica / *Electro-Hydraulic Pump*
Pompa Elettro-Idraulica con Comando Remoto / *Electro-Hydraulic Pump w/Remote*

Portata / *Max load capacity*

Altezza Max / *Max Height*

Altezza Min. / *Min. Height*

Posizioni Sicura / *Safety Position*

Dimensione Piano Sollevamento / *Tabletop size*

Dimens. Rampa di Salita / *Run-up Ramp size*

Ingombro Totale Sollevatore / *Overall Dimensions*

Ingombro Totale piano sollev. / *Tabletop overall dimensions*

Peso / *Weight*

1000 Kg / 2204 Lbs

100 cm / 3.2 Ft

20 cm / 7.8 Inch.

6

215x120 cm / 7.1x4 Ft

82x24 cm / 2.6 Ft x 9.4 Inch

225x120 cm / 7,5x4 Ft

215x120 cm / 7.1x4 Ft

300 Kg / 661 Lbs

Centralina Elettro-Idraulica
Electro-Hydraulic Power Unit

Potenza / *Power*
Europa / *Europe*
Giappone / *Japan*
America / *USA*

1,1 Kw
230 Volts - 50 Hz
200 Volts - 50/60 Hz
110 Volts - 60 Hz

DOTAZIONE DI SERIE / *STD EQUIP.*

Rampe / *Run-up Ramps* 2 pcs
Imballo Std. / *Std. Packing*
Scat. Cartone con pallet Legno/
Cardboard w/wooden crate
Fermaruota / *Wheel stop* 2 pcs



POWER IN ACTION

LA VERSIONE DEL GARDEN 754 (750 kg di sollevamento) è quella che si è più dimostrata versatile per usi industriali, dove è apprezzato da anni come valido strumento di movimentazione di materiali pesanti che devono essere sollevati per l'assemblaggio. Uno dei modelli più venduti nel Nord Europeo, utilizzato per interventi su trattorini tagliaerba ma anche per motoslitte.

THE GARDEN 754 VERSION (750 kg load capacity) has proved to be most versatile for industrial use, where it has been appreciated for years as a valid tools for handling heavy materials that must be lifted for assembly. One of the most sold models in Northern Europe, where it is used for service activities on riding lawn mowers but also on snowmobiles.



GARDEN 754



G-002	Pompa ad Aria / Air Pump
G-003	Pompa Elettro-Idraulica / Electro-Hydraulic Pump
G-004/R	Pompa Elettro-Idraulica con Comando Remoto / Electro-Hydraulic Pump w/Remote

Portata / Max load capacity	750 Kg / 1650 Lbs
Altezza Max / Max Height	130 cm / 4.2 Ft
Altezza Min. / Min. Height	20 cm / 7.8 Inch.
Posizioni Sicura / Safety Position	8
Dimensione Piano Sollevamento / Tabletop size	215x100 cm / 7.1x3.2 Ft
Dimens. Rampa di Salita / Run-up Ramp size	82x24 cm / 2.6 Ft x 9.4 Inch
Ingombro Totale Sollevatore / Overall Dimensions	225x100 cm / 7,5x3.2 Ft
Peso / Weight	280 Kg / 617 Lbs



Centralina Elettro-Idraulica
Electro-Hydraulic Power Unit

Potenza / Power	1,1 Kw
Europa / Europe	230 Volts - 50 Hz
Giappone / Japan	200 Volts - 50/60 Hz
America / USA	110 Volts - 60 Hz
	2 pcs

Pompa ad Aria / Air Pump

Pressione Aria / Air Pressure	7-10 Bar
Consumo Aria / Air Consumption	300L/Min

DOTAZIONE DI SERIE / STD EQUIP.

Rampe / Run-up Ramps	2 pcs
Imballo Std. / Std. Packing	
Scat. Cartone con pallet Legno/ Cardboard w/wooden crate	
Fermaruota / Wheel stop	2 pcs

SWING IT UP !

UNICO NEL SUO GENERE IL FROG 500 è un sollevatore progettato per la manutenzione dei veicoli a quattro ruote, come Quad, ATV e trattorini tosaerba. E' dotato di due pedane elevabili e basculanti che possono salire fino a 100 cm nella parte anteriore ed a 155 cm nella parte posteriore. Questa esclusiva soluzione progettistica permette un accesso alla parte inferiore del veicolo molto più agevole e consente di intervenire in piena sicurezza e comfort e con tempi di lavoro inferiori.

A LIFT UNIQUE IN ITS KIND, Frog 500 was designed for maintenance of 4 wheeled vehicles, such as Quads, ATVs and riding lawn mowers. It is equipped with two elevating and tilting platforms that can raise up to 100 cm in the front end and to 155 cm in the rear end. This exclusive design solution allows a much easier access to the lower part of the vehicle and to operate in full safety and comfort and with a shorter working times.

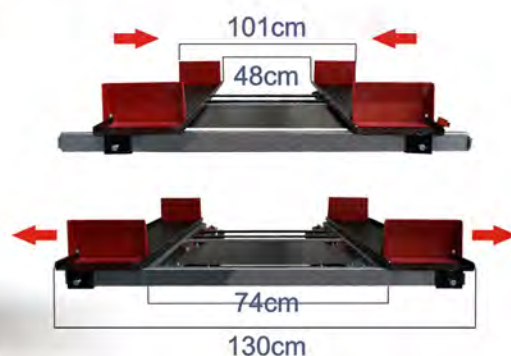

FROG 500



F500-002
F500-003
F500-004/R

Pompa ad Aria / *Air Pump*
Pompa Elettro-Idraulica / *Electro-Hydraulic Pump*
Pompa Elettro-Idraulica con Comando Remoto / *Electro-Hydraulic Pump w/Remote*

Portata / *Max load capacity*

Altezza Max (posiz. orizzontale) / *Max Height (horizontal pos.)*

Altezza Min. / *Min. Height*

Altezza Max (parte anteriore) / *Max Height (front end)*

Altezza Max (parte posteriore) / *Max Height (rear end)*

Posizioni Sicura / *Safety Position*

Distanza Max. binari (esterna) / *Max. rails distance (external)*

Distanza Min. binari (esterna) / *Min. rails distance (external)*

Dimensione Binario / *Rails Size*

Distanza Max. Binario (interna) / *Max. Rail distance (internal)*

Distanza Min. Binario (interna) / *Min. Rail distance (internal)*

Dimensione Rampe Salita/ *Run-up Ramp sizes*

Ingombro Totale Sollevatore / *Overall Dimensions*

Peso / *Weight*

500 Kg / 1102 Lbs

80 cm / 2.6 Ft

20 cm / 7.8 Inch.

100 cm / 3.2 Ft

155 cm / 5 Ft

3

130 cm / 4.2 Ft

101 cm / 3.3 Ft

200x26 cm / 6.5 Ft x 10 Inch

74 cm / 2.4 Ft

48 cm / 1.6 Ft

82x24 cm / 2.7 Ft x 9 Inch

200x130 cm / 6,5x4.2 Ft

285 Kg / 628 Lbs



Centralina Elettro-Idraulica
Electro-Hydraulic Power Unit

Potenza / *Power* 1,1 Kw
Europa / *Europe* 230 Volts - 50 Hz
Giappone / *Japan* 200 Volts - 50/60 Hz
America / *USA* 110 Volts - 60 Hz

Pompa ad Aria / *Air Pump*

Pressione Aria / *Air Pressure* 7-10 Bar
Consumo Aria / *Air Consumption* 300L/Min

DOTAZIONE DI SERIE / *STD EQUIP.*

Rampe / *Run-up Ramps* 2 pcs
Imballo Std. Cassa Legno
Std. Package Wood box 207x132x35cm 300 kg
Fermaruota / *Wheel stop* 4 pcs

VERSIONI DA INCASSO FLOOR VERSION

I MODELLI ABSOLUTE Gate/Split 756 sono anche disponibili nella versione da incasso nel pavimento. Questo tipo di soluzione rende più agevole il posizionamento delle moto ed ottimizza l'utilizzo dello spazio interno dell'officina o dello show-room. Su richiesta è possibile fare anche altri modelli in versione floor, come il Racing 350, Sport 500 gate e il Max Gate 516.

The Absolute 756 Gate / Split models are available in a special version recessed into the floor (pit). This kind of installing solution makes it easier for operators to position the motorcycle on the lift table top as well as optimizing space inside the workshop or showroom. On demand, other models can also be produced in floor version, such as the Racing 350, the Sport 500 Gate and the Max Gate 516.

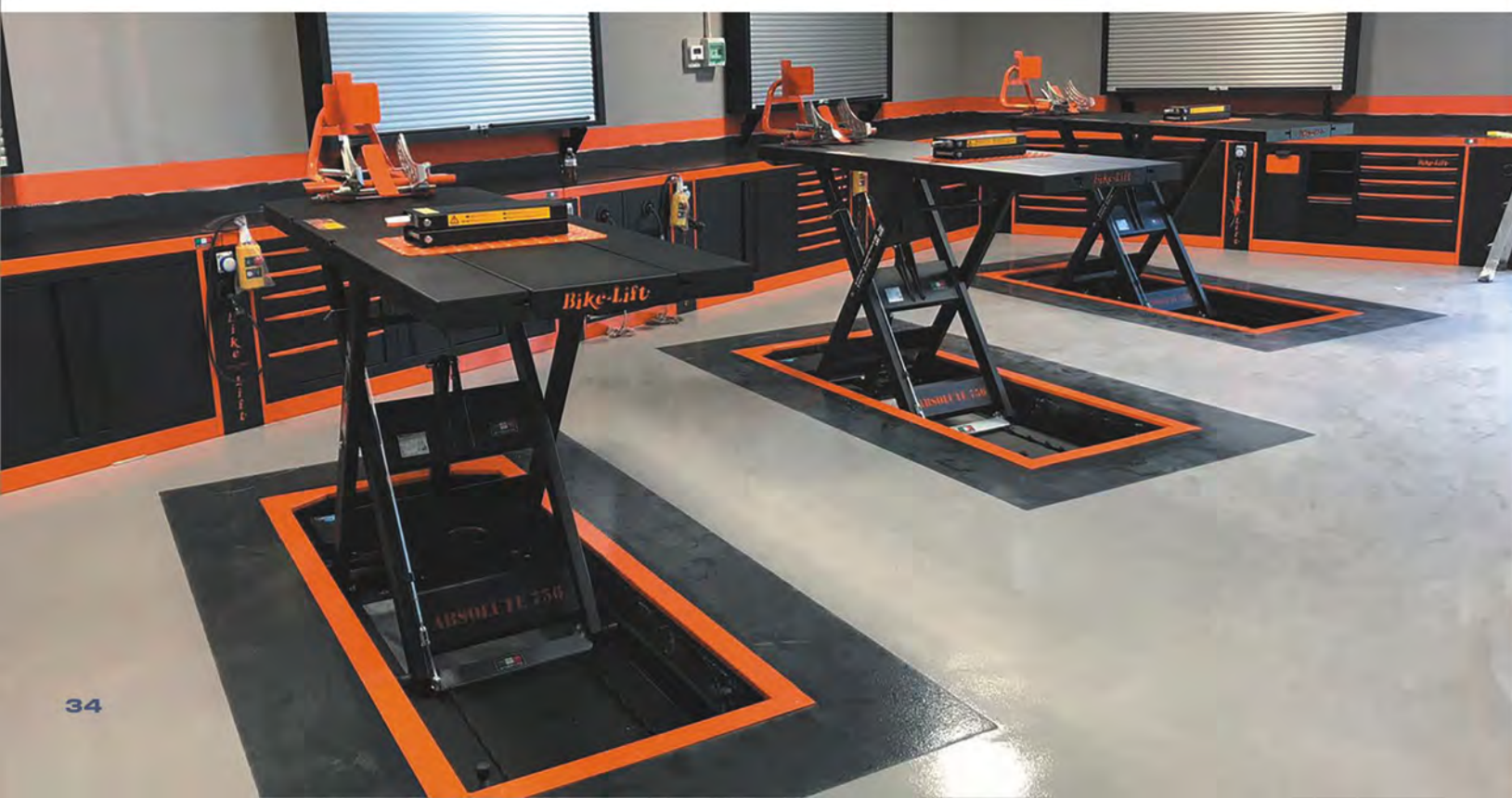



**Accessori
Sollevatori
Lifts
Accessories**

Ali di allargamento
Extension Side Wings



Codice / Item	SW-756
Modello / Model	AG-756
Dimensioni/Dimensions	27.5X212X60CM 0.9X6.96X1.9 FT

Codice / Item	SW-516
Modello / Model	M516/MG516
Dimensioni/Dimensions	27.5X210X50CM 0.9X6.89X1.6 FT

Sicurezza Pneumatica
Pneumatic Safety



Codice / Item	PS-004
---------------	--------

Optional applicabile a tutti i sollevatori con pompa elettro-idraulica
Optional applicable to all models with electro-hydraulic pump



Ali Speciali Pivottanti
Pivoting Extension Wings



Codice / Item	PSW-516
Modello / Model	M516/MG516
Dotazione Standard	2 Fermaruota 2 Rampe di salita 4 Ali fisse 2 Ali mobili
Standard Equipment	2 Wheel stoppers 2 Run-up ramps 4 Side fixed wings 2 Pivoting wings

Dimensioni / Dimensions

Ali Fisse / Side Wings

A	83cm/2.7ft
B	52.5cm/1.72ft
C	30cm/0.99ft

Ali Mobili / Pivoting Wings

A	104cm/3.4ft
B	43cm/1.41ft
C	30cm/0.99ft

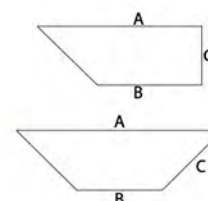



Guide Scorrevoli
Sliding hooks and rails

Codice / Item

Modello / Model

RAIL-350
RAIL-516

R-350
M516/MG516/SG500
MA504

RAIL-756
RAIL-756/S

AG-756
AS-756

Estensioni laterali per veicoli a 3 ruote
Side Extension for 3 wheeled vehicles

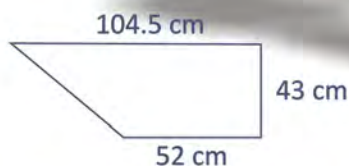

Codice / Item

Modello / Model

SW-SPIDER

AG-756/AS756



Kit telecomando remoto
Remote control kit



Codice / Item

Modello / Model

LC-003

Sollevatori dal
2015 in poi
*Lifts from 2015
ahead*

Adattatori in Gomma
Rubber Adapters



Codice / Item

Modello / Model

RA-20
RA-40
RA-60

140x120x20mm
140x120x40mm
140x120x60mm

Rampa per veicoli a 3 ruote
Extension run-up ramp for 3 wheeled vehicles



Codice / Item	R-MP3
Dimensioni / Dimensions	77x110 cm
Modello / Model	AG756/MG516 G754



Piastra aggancio rapido morsa W-36S
W-36S wheel clamp quick set



Codice / Item QRP

Attenzione : perni di fissaggio non inclusi.
Utilizzabile solo per modelli prodotti prima del 2014
Warning : Locking pins not included.
Applicable only for lifts produced until 2014.

Tappeti protezione in gomma
Protection Rubber mats



RM

Codice / Item	RM
	33X44.5 cm
Codice / Item	RM-SMALL
	50X16.5 cm

RM-SMALL





Piastra Protezione anti-scivolo
Anti-skid protection plate

Codice / Item	PZA
Modello / Model	TUTTI/ALL
Dimensioni/Dimensions	55x34 cm



Pedaliere comandi sollevatore
Foot pedal control for lifts

Codice / Item	FC/EL-CV
---------------	----------



Pulsantiera con magnete
Hand control with magnet

Codice / Item	HC
---------------	----



Pompa ad aria 200 bar
Air Pump 200 bar

Codice / Item	AP
---------------	----



Pompa a pedale
Foot Pump

Codice / Item	FP
---------------	----

Protection Mats **TAPPETI DI PROTEZIONE**

I tappeti di protezione sono tutti Made in Italy. Il materiale ha una densità di 800 gr per metro quadrato ed è gommato sulla parte interna per evitare scivolamenti. E' completamente lavabile e serve a prevenire graffi o macchie sui piani di lavoro dei sollevatori o banchi per officina. Oltre a proteggere dal graffi e macchie evita il rimbalzamento di eventuali parti metalliche come viti, dadi ecc. che altrimenti cadrebbero fuori dal piano di lavoro con il rischio di perderle. Il materiale ha una notevole capacità di assorbimento di liquidi e fluidi. All'esterno una bordatura previene l'usura e le lacerazioni che con il tempo si potrebbero formare. I tappeti sono stampati con il logo Bike Lift ma su richiesta possono essere personalizzati con quantitativi minimi d'ordine. Prodotto con feltro 100% poliestere, combustibile ma non infiammabile, da veli cardati e legati meccanicamente mediante aghi ed abbinato a gomma base lattice naturale al 100%.

The protection mats are all Made in Italy. The material has a density of 800gr per square meter and is rubber-coated in the bottom side for anti-skid purposes. It is 100% washable and protects against scratches and spots over tabletops of lifts and workbenches. In addition to that, it prevents metallic parts like screws or bolts that may get lost, from falling off the lift or workbench tabletop. The material has a considerable absorbing capacity for liquids and fluids. The mat edges are seamed so as to avoid any wear or tear during usage. The mats are printed with the Bike Lift logo and can be customized upon request (MOQ's to be agreed). Made of 100% polyester felt, combustible but not flammable, from carded and strapped layers mechanically knitted and bound with 100% natural latex base rubber.

Codice / Item	Serial No.	Modello/Model	Bordo/Edge color	Codice / Item	Serial No.	Modello/Model	Bordo/Edge color
BL-LC/756	911040100100	Absolute 756	Rosso/Red	BL-TC/2000	911040100400	MF-BL 2000	Rosso/Red
BL-LC/756	911040100150	Absolute 756	Grigio/Grey	BL-TC/1620	911040100500	MF-BL 1620	Grigio/Grey
BL-LC/516	911040100200	Max / Master	Rosso/Red	BL-TC/1000	911040100600	MF-BL 1000	Grigio/Grey
BL-LC/516	911040100250	Max / Master	Grigio/Grey	BL-TC/ANG	911040100800	MF-PANG	Rosso/Red
BL-LC/SPORT	911040100300	Sport	Rosso/Red	BL-TC/ALBN	911040100700	AL-BN	Rosso/Red
BL-LC/SPORT	911040100350	Sport	Grigio/Grey				



SOLLEVATORI CENTRALI

Central lifts



CENTRAL STABILITY

PROGETTATO DA BIKE LIFT OLTRE 15 ANNI FA, il modello KODIAK 500 resta ancora oggi un sollevatore molto speciale sia in termini meccanici, progettuali e operativi. Il piano di sollevamento può ruotare di 360° quindi fornisce la migliore accessibilità durante l'intervento di manutenzione, sia su moto off-road che su Quads e ATV. Il sollevamento del veicolo avviene posizionando il piano di sollevamento al centro del telaio della moto o del quad, lasciando quindi completamente libere le ruote, le sospensioni e la trasmissione. Il KODIAK è estremamente stabile, anche alla massima estensione di 130 cm, grazie alla perfetta distribuzione dei carichi ed allo studio del baricentro variabile.

DESIGNED BY BIKE-LIFT MORE THAN 15 YEARS AGO, the KODIAK 500 nowadays still remains a very special lift in mechanical, design and operational terms. Its lifting platform can rotate 360° and therefore guarantees the best accessibility to the vehicle during servicing activities, be it an off-road bike or Quad chassis, leaving the wheels, suspensions and transmission completely free. The KODIAK is extremely stable, even at the maximum height of 130 cm, thanks to its perfect load distribution and the study of the variable barycenter.



KODIAK

500



KD-001	Pompa a Pedale / <i>Foot Pump</i>
KD-002	Pompa ad Aria / <i>Air Pump</i>
KD-003	Pompa Elettro-Idraulica / <i>Electro-Hydraulic Pump</i>
KD-004/R	Pompa Elettro-Idraulica con Comando Remoto / <i>Electro-Hydraulic Pump w/Remote</i>

Portata / <i>Max load capacity</i>	500 Kg / 1102 Lbs
Altezza Massima / <i>Max Height</i>	130 cm / 4.3 Ft
Altezza Minima / <i>Min. Height</i>	20 cm / 7.8 Inch.
Posizioni Sicura / <i>Safety Position</i>	11
Ingombro Totale Sollevatore / <i>Overall Dimensions</i>	190x78 cm / 6x2.5 Ft
Dimens. piano di sollevam./ <i>Tabletop sizes</i>	45x33 cm / 1.5x1 Ft
Peso / <i>Weight</i>	110 Kg / 242 Lbs



Centralina Elettro-Idraulica
Electro-Hydraulic Power Unit

Potenza / <i>Power</i>	1,1 Kw
Europa / <i>Europe</i>	230 Volts - 50 Hz
Giappone / <i>Japan</i>	200 Volts - 50/60 Hz
America / <i>USA</i>	110 Volts - 60 Hz

Pompa ad Aria / *Air Pump*

Pressione Aria / <i>Air Pressure</i>	7-10 Bar
Consumo Aria / <i>Air Consumption</i>	300L/Min

Imballo Std. / *Std. Packing*

Scat. cartone con pallet legno / <i>Cardboard w/ wooden crane</i>	
Tappeto Gomma/Rubber Mat	1 pc

TINY BUT POWERFUL

IL PIU' PICCOLO SOLLEVATORE nella nostra gamma, progettato per l'utilizzo in spazi ristretti di intervento su Quad e ATV. La grande capacità di sollevamento fino a 400 kg permette di operare con accuratezza e sicurezza su ogni lato del veicolo. E' dotato di ruote e maniglia a sgancio rapido per la movimentazione all'interno dell'officina. Disponibile con pompa a pedale o con centralina elettro-idraulica.

THE SMALLEST LIFT in our range, designed for use on Quads and ATVs in narrow operating areas. Its high capacity up to 400 kg allows to work accurately and safely on each side of the vehicle. It is equipped with wheels and a quick-release handle for an easy displacement of the lift inside the workshop. It is available with foot-pump or electro-hydraulic pump unit with hand control.



HQL-001

HQL 400



HQL-001
HQL-003

Pompa a Pedale / *Foot Pump*

Pompa Elettro-Idraulica / *Electro-Hydraulic Pump*

Portata / *Max load capacity*

Altezza Massima / *Max Height*

Altezza Minima / *Min. Height*

Posizioni Sicura / *Safety Position*

Dimens. piano di sollevam./ *Tabletop sizes*

Ingombro Totale Versione 003/*Overall Dimensions type 003*

Ingombro Totale Versione 001/*Overall Dimensions type 001*

Dimens. appoggio gomma / *Rubber mat size*

Peso / *Weight*

400 Kg / 880 Lbs

80 cm / 2.6 Ft

23 cm / 9 Inch.

5

53x36 cm / 20x14 Inch

88x50 cm / 2.8x1.6 Ft

78x50 cm / 2.5x1.6 Ft

45x33 cm / 17x13 Inch

65 Kg / 143 Lbs



HQL-003

Centralina Elettro-Idraulica
Electro-Hydraulic Power Unit

Potenza / *Power* 1,1 Kw
Europa / *Europe* 230 Volts - 50 Hz
Giappone / *Japan* 200 Volts - 50/60 Hz
America / *USA* 110 Volts - 60 Hz

DOTAZIONE DI SERIE / *STD EQUIP.*

Imballo Std. / *Std. Packing*
Scat. cartone con pallet legno /
Cardboard w/ wooden crane

Maniglia di trasporto /
Transport Handle 1 pc
Tappeto Gomma /
Rubber Mat 1 pc

CFL 500

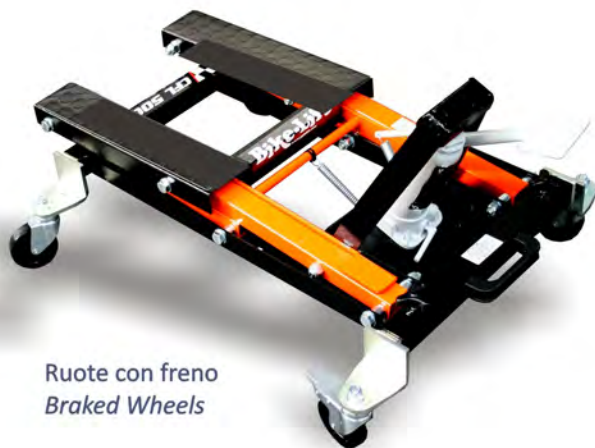

Ruote con freno
Braked Wheels

Codice / Item

CFL-500/Q

Larghezza / Width
Portata Max./Max Load
Azionamento/Action

38 cm
500 kg
pompa pedale
foot pump



Altezza max./Max. Height
Altezza min./Min. Height
Posiz. Sicura/Safety locks

55 cm
21 cm
3



Versione Quad e ATV
Quad & ATV Model

Codice / Item

CFL-500

Larghezza / Width
Portata Max./Max Load
Azionamento/Action

38 cm
500 kg
pompa pedale
foot pump



Altezza max./Max. Height
Altezza min./Min. Height
Posiz. Sicura/Safety locks

45 cm
11 cm
3



Versione Custom & Cruiser
Custom & Cruiser Model

Ruote con freno
Braked Wheels



HXL 160



Codice / Item	HXL-160
Larghezza / Width	33X45 cm
Portata Max./Max Load	160 kg
Azionamento/Action	pompa pedale foot pump
Altezza max./Max. Height	89 cm
Altezza min./Min. Height	39 cm
Molle Sicur./ Safety Hooks	2
Pos.Sicurezza/Safety Lock	4



MCL-20

MCL-30

WARNING

- NON UTILIZZARE MAI CHIAVI AD IMPULSO. POTREBBERO DANNEGGIARE LA VITE ED IL CUSCINETTO.
- NEVER USE IMPACT WRENCHES AS THEY WOULD DAMAGE THE THREADS AND BEARINGS.
- NE JAMAIS UTILISER DE CLÉS A CHOC. ELLES POURRAIENT ENDOMMAGER LA VIS ET LE COUSSINET A BILLES.
- BEWITZEN SIE NIEMALS SCHLAGSCHRAUBEN MIT DRUCKLUFTANTRIEB ZUR BETÄTIGUNG. SIE KÖNNTEN DIE SPINDEL ODER DAS KUGELLAGER BESCHÄDIGEN.

DANGER

ASSICURARE LA MOTO CON CINGHIE DI SICUREZZA

FASTEN THE MOTORCYCLE WITH TIE DOWN

Codice / Item MCL-30

Larghezza / Width 25 cm
 Altezza Max/Max Height 35 cm
 Altezza Min./Min. Height 8.5 cm
 Lunghezza/Length 40 cm
 Portata Max/Max Load 500 kg
 Azionamento Manuale
 Manual Action



MCL-30

Codice / Item MCL-20

Larghezza / Width 15 cm
 Altezza Max/Max Height 35 cm
 Altezza Min./Min. Height 8.5 cm
 Lunghezza/Length 40 cm
 Portata Max/Max Load 500 kg
 Azionamento Manuale
 Manual Action



MCL-20

Supporti opzionali utilizzabili solo con il modello MCL-20 necessari quando non è possibile alzare la moto centralmente e bisogna quindi lavorare direttamente sulla parte inferiore del telaio.

Codice - Item
MCL-03A

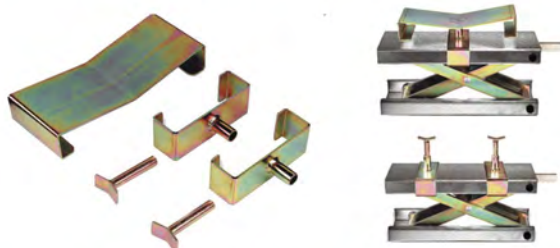

Optional adapters only for MCL-20, to be used when it is not possible to lift the vehicle by its centre and so it is necessary to work directly on the bottom part of the frame.





MORSE
Wheel Clamps

W-38S



Codice / Item W-38 S

Regolabile/Adjustable
Azionamento Automatico / Automatic

Max Ruota/Max Wheel 21"
Min. Ruota/Min. Wheel 12"
Peso / Weight 12 kg
Azionamento/Action Automatic



W-42



Regolabile
Fully Adjustable

Codice / Item W-42

Max Ruota/Max Wheel 21"
Min. Ruota/Min. Wheel 12"
Dimensioni/Dimensions 36x61x40.5 cm
Peso / Weight 12 kg
Azionamento/Action Automatic



W-40



Codice / Item W-40

Apertura Max/Max Opening Range 225 mm
Apertura Min./Min. Opening Range 60 mm
Azionamento/Action Manual





W-36S



Codice / Item

W-36 S

Apertura Max/Max Opening Range
Apertura Min./Min. Opening Range
Azionamento/Action

205 mm
70 mm
Automatic



W-32N



Codice / Item

W-32 N

Apertura Max/Max Opening Range
Apertura Min./Min. Opening Range
Azionamento/Action

205 mm
55 mm
Pneumatic



W-34N



Codice / Item

W-34 N

Apertura Max/Max Opening Range
Apertura Min./Min. Opening Range
Azionamento/Action

215 mm
75 mm
Manual

MORSE PER FURGONI E TRAILER

WHEEL CLAMPS FOR VAN & TRAILERS

W-36F



Codice / Item	W-36 F
Lunghezza / Length	69 cm
Altezza / Height	43 cm
Peso / Weight	14 kg
Azionamento / Action	Automatic



W-38C



Codice / Item	W-38 C
Lunghezza / Length	67 cm
Altezza / Height	43 cm
Peso / Weight	8 kg
Azionamento / Action	Automatic



W-42



Codice / Item	W-42
Max Ruota/Max Wheel	21"
Min. Ruota/Min. Wheel	12"
Dimensioni/Dimensions	36x61x40.5 cm
Peso / Weight	12 kg
Azionamento/Action	Automatic



Regolabile
Fully Adjustable

W-28F



Codice / Item	W-28 F
Apertura Max/Max Opening Range	143 mm
Apertura Min./Min. Opening Range	51 mm
Peso / Weight	10 kg
Azionamento/Action	Automatic





**ARREDAMENTO
OFFICINA
WORKSHOP
FURNITURE**

MODORFLEX

Produced by *Bike-Lift*





L'ARREDAMENTO DELL'OFFICINA è un elemento essenziale in una moderna struttura di assistenza e riparazione moto. Modoflex è il partner ideale con cui condividere e sviluppare le vostre idee e la vostra visione di officina funzionale e moderna. Dalla progettazione alla realizzazione di parti speciali, sagome personalizzate che seguono lo schema perimetrale del vostro spazio: ogni dettaglio si trasforma da semplice idea a prodotto finito ed assemblato sul posto.

Questo è MODOFLEX, il modo più semplice con cui un'idea diventa una realtà funzionale, accogliente e produttiva.

THE FURNITURE ELEMENTS INSIDE THE WORKSHOP are essential for a modern structure of a motorcycle servicing and repair. Modoflex is the ideal partner for you to share and develop your ideas and your vision of a modern and functional workshop.

From the projecting stage to the manufacturing of special parts, customized frames that follow the perimetral scheme of your space; every imagine detail transforms into a ready made and assembled on-site product.

This is MODOFLEX, the easiest way to turn your ideas into a functional, styled and productive reality.

Banchi e Moduli MODOFlex
MODOFlex Workbenches and modules

Codice / Item	MF-BL 2000-01M	MF-BL 2000-01V	MF-BL 2000-03	MF-BL 2000-01V-L2
Versione / Version	Moduli/Modules	Ripiano/Shelf	Ripiano+Modulo/ Shelf+Module	Doppio Ripiano Double Shelf
Spazio Int./Internal Space	1750x695 mm	1750x695 mm	200x80x90h cm	200x80x90h cm
Dimensioni/Dimensions	200x80x90h cm	200x80x90h cm	200x80x90h cm	200x80x90h cm

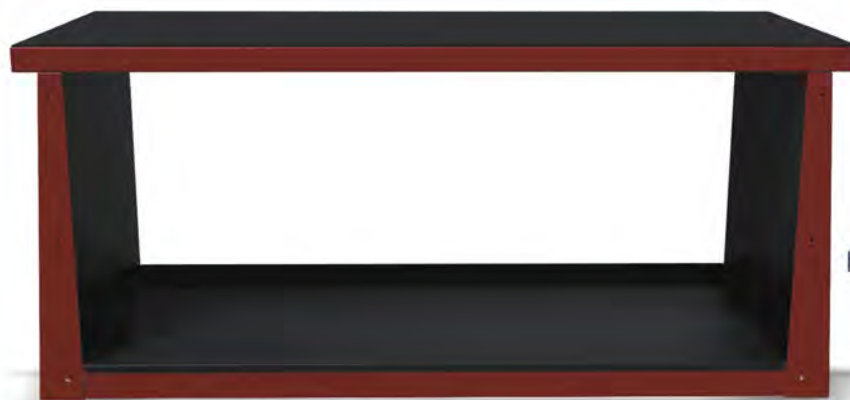

MF-BL 2000-01V

MF-BL 2000-01M



MF-BL 2000-03



MF-BL 2000-01V-L2

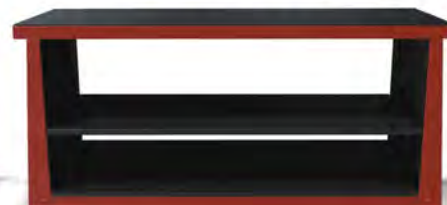

* modulo non incluso/module not included



Banco per carrello
(moduli non inclusi)
Workbench for drawers cabin
(modules not included)



Cassettiera c/ruote con
5 cassetti
5 Drawers cabin w/wheels
for workbench



Banco a Penisola
T-Shaped workbench

Codice / Item	Dimensioni/Dimensions
MF-BL 2000-1MC	200x80x90h cm
MF-BL 1620-1MC	162x80x90h cm
MF-BL 1000-1MC	100x80x90h cm

Codice / Item	Dimensioni/Dimensions
MF-CB	67x46x81h cm

Codice / Item	Dimensioni/Dimensions
MF-BL 2000 PE	290x80x90h cm

Codice / Item	MF-BL 1620-01M	MF-BL 1620-01V	MF-BL 1620-03	MF-BL 1620-01V-L2
Versione / Version	Moduli/Modules	Ripiano/Shelf	Ripiano+Modulo/ Shelf+Module	Doppio Ripiano Double Shelf
Spazio Int./Internal Space	1375x695 mm	1375x695 mm	162x80x90h cm	162x80x90h cm
Dimensioni/Dimensions	162x80x90h cm	162x80x90h cm	162x80x90h cm	162x80x90h cm

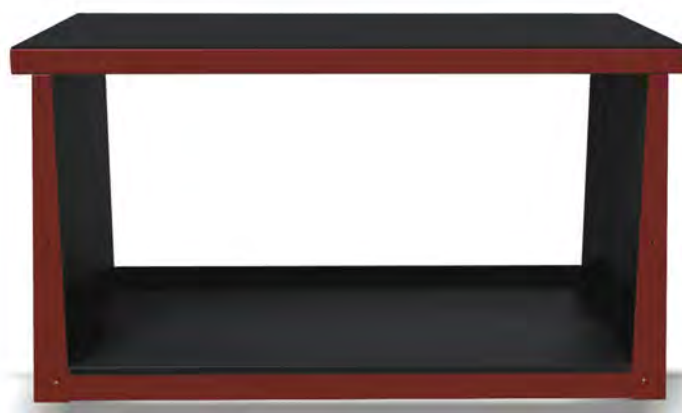

MF-BL 1620-01V

MF-BL 1620-01M



MF-BL 1620-03



*modulo non incluso/module not included

MF-BL 1620-01V-L2

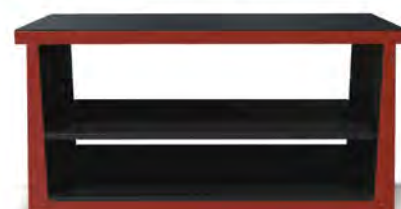

Codice / Item	MF-BL 1000-01M	MF-BL 1000-01V	MF-BL 1000-01V-L2
Versione / Version	Moduli/Modules	Ripiano/Shelf	Doppio Ripiano Double Shelf
Spazio Int./Internal Space	1375x695 mm	1375x695 mm	100x80x90h cm
Dimensioni/Dimensions	100x80x90h cm	100x80x90h cm	100x80x90h cm



MF-BL 1000-01M



MF-BL 1000-01V-L2



MF-BL 1000-01V

MODULI - MODULES

Con serratura / With lock



Codice / Item MF-BL M1 Modulo 7 cassetti
7 Drawers Module

Con serratura / With lock



Codice / Item MF-BL M2 Modulo 5 cassetti
5 Drawers Module



Codice / Item MF-BL M3 Modulo Vano Sportello
con ripiano regolabile
Tool Tray w/door and
adjustable tray



Codice / Item MF-BL M4



Codice / Item MF-BL M4-XL



Codice / Item MF-BL M5



Codice / Item MF-BL M6

Modulo Bidone
Litter Module

Modulo Bidone XL
Wide Litter Module

Modulo 2 Ripiani
2 Shelves Module

Modulo Rotolo Carta
Paper Roller Module



Codice / Item MF-BL M7



Codice / Item MF-BL M8



Codice / Item MF-BL M6



Codice / Item MF-BL M13

Modulo Olio c/pistola
e arrotolatore 15 mt
Oil Module w/oil gun
and 15mt hose reel

Modulo Aria/Elettr. con
arrotolatore 10mt e presa/
Air/Electr. Module with air
hose and electric plug

Modulo Comandi Cu500/
CU500 Controls Module

Modulo 6 Cassetti
6 Drawers Module



Codice / Item MF-BL M9 Modulo 2 Sportelli+
ripiano regolabile
2 Doors w/shelf and
adjustable tray module



Codice / Item MF-BL M10 Modulo 2 Sportelli+
ripiano regolabile
2 Doors w/shelf and
adjustable tray module

Con serratura / With lock



Codice / Item MF-BL M12 Modulo 5 Cass. Largo
Wide 5 Drawers Mod.

SCHEMA COMPOSIZIONE BANCHI
WORKBENCHES COMPOSITION SCHEME

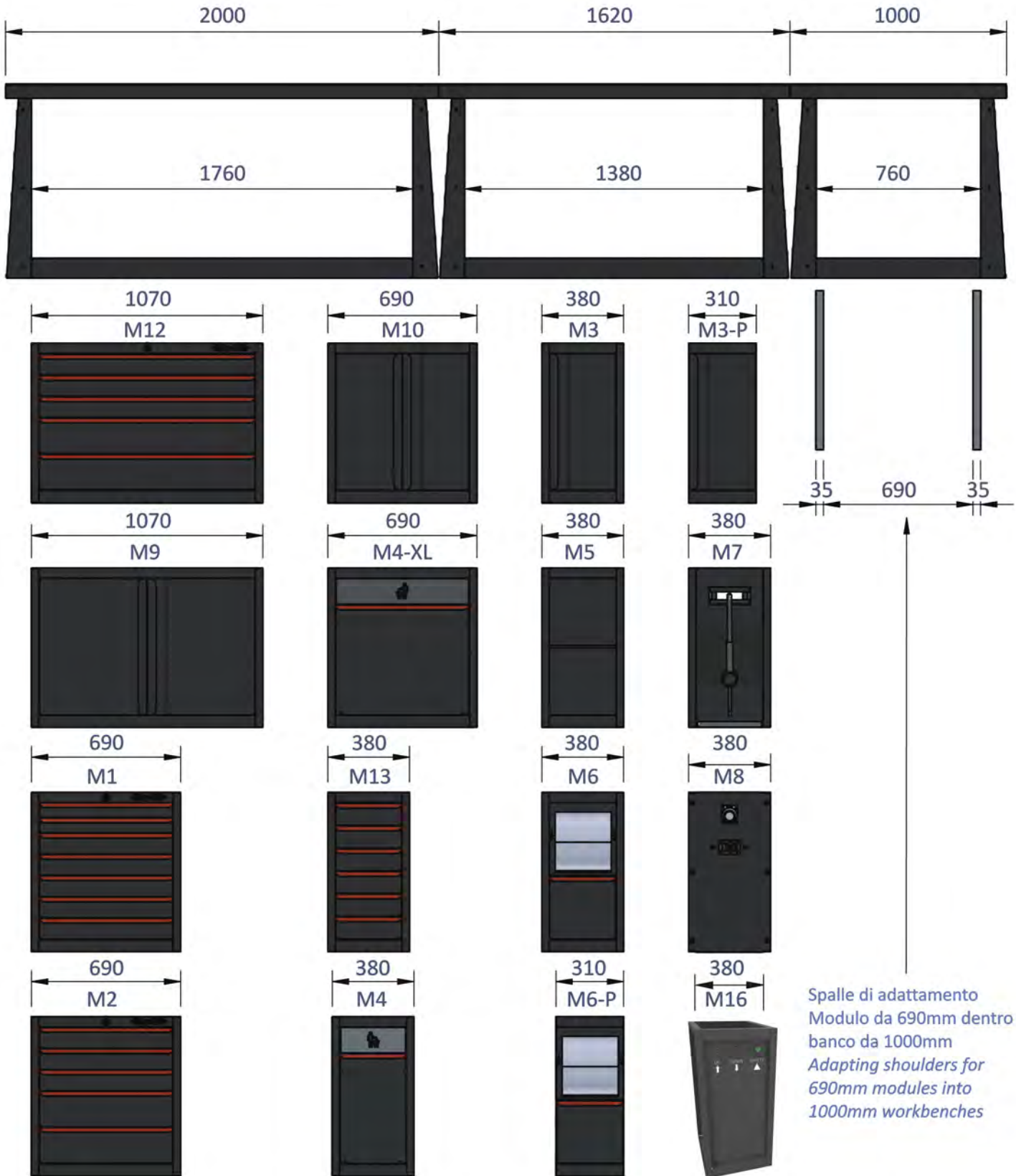

PANNELLI DI CONGIUNZIONE E UTILITA'
JUNCTION AND UTILITY PANELS



Pannello unione banchi con tubo aria e presa di corrente (inclusi)

Connection panel with 10mt air hose and electric plug (included)

Codice / Item	Dimensioni/Dimensions
MF-PU-AE	190x25x825mm



Pannello unione banchi con tre prese di corrente

Connection panel with 3 AC plugs electric plugs (included)

Codice / Item	Dimensioni/Dimensions
MF-PU-3	190x25x825mm



Pannello unione banchi con tubo aria e arrotolatore elettrico (inclusi)

Connection panel with 10mt air hose and 15mt electric reel (included)

Codice / Item	Dimensioni/Dimensions
MF-PU-AE2	190x25x825mm



Pannello unione banchi con presa Schuko e cavo LAN e arrot. aria 10 mt (inclusi)

Connection panel with Schuko plug, LAN cable and air hose 10 mt (included)

Codice / Item	Dimensioni/Dimensions
MF-PU-ASL	190x25x825mm



Pannello angolare unione banchi con presa e tubo aria (inclusi)

Corner connection panel with electric plug and 10mt air hose(included)

Codice / Item
MF-PU-AEA



Pannello unione banchi con logo

Codice / Item
MF-PU-U



Pannello angolare unione banchi
Corner connection panel
Codice / Item
MF-PU-A

Tutti i pannelli con logo possono essere personalizzati a richiesta.
All panels with logo can be customized



Pannello angolare unione banchi con doppio arrotolatore aria 10mt ed elettrico 10 mt.
Corner connection panel with air hose 10m and electric cable reel 10m.

Codice / Item
MF-PU-AEA2



Codice / Item
MF-P-INOX

Piano di lavoro e strutture completamente in acciaio inox disponibili per tutti i nostri banchi di lavoro
Worktable and frame structures entirely made of stainless steel are available for all our workbenches

Codice / Item
MF-C-INOX

Coperture del piano di lavoro in acciaio inox disponibili per tutti i nostri banchi di lavoro.
Worktable covers (to fit over the iron tabletop) made of stainless steel are available for all our workbenches

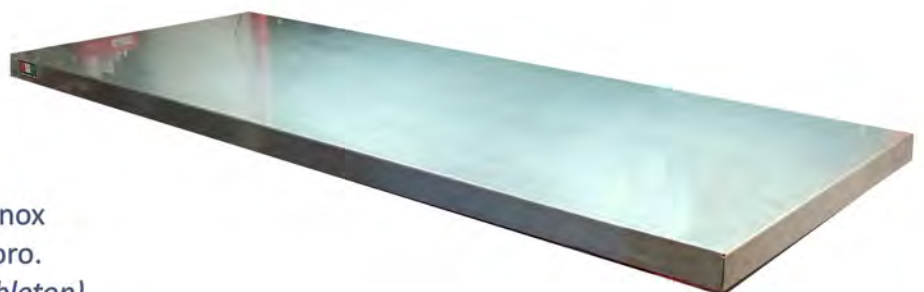

ARMADI Wardrobes

Codice / Item

MF-AR50



Armadio con larghezza 50 cm da utilizzare come chiusura laterale di una composizione. La porta è dotata di chiusure self-closing e gli scaffali interni sono completamente regolabili in altezza. Dimensioni 200x50x70 cm e peso di 60kg.

Codice / Item

MF-AR



Armadio con larghezza 100 cm con doppia porta. Le porte sono dotate di chiusure self-closing e gli scaffali interni sono completamente regolabili in altezza. Dimensioni 200x100x70 cm e peso di 100kg.

ARREDAMENTO CON ALTEZZA 100CM H100 FURNITURE RANGE



E' disponibile per tutta la gamma MODOFLEX anche l'arredamento con altezza 100cm anziché 90cm, creato per le esigenze di ergonomia e comfort sul lavoro. La maggiore altezza permette agli operatori con statura medio-alta ed alta di poter lavorare sul piano di lavoro con una posizione delle braccia ed una postura del busto più ergonomica.

Essendo i nostri banchi di lavoro profondi 80cm, per permettere con facilità di raggiungere sia le griglie porta attrezzi che i pensili ed il loro contenuto, sulla base della struttura dei banchi è stata creata una nicchia di 10cm che consente il passaggio delle scarpe da lavoro e quindi avvicina l'operatore agli attrezzi ed ai moduli alti della composizione.

Come per tutta la gamma MODOFLEX, anche la versione H100 può essere personalizzata con colori RAL a scelta del cliente,



It is now available for all the MODOFLEX furniture range the new H100 version, developed to comply with the standards of comfort and ergonomomy of the working place. Le increased height allows the operators with medium-high / high stature to work in the tabletop with an arms position and a torso posture much more ergonomic. Being our workbenches built with a width of 80cm, in order to allow to reach the wall grids and/or the cupboards and its contents, in the base structure of the workbenches it has been created a niche with a width of 10cm that allows to put the working shoes inside and so to come near the operator to the tools and the modules on top of the workshop composition.

As for the complete MODOFLEX range of furniture, the customer can choose the RAL color of the modules and workbenches also for the H100 version.



PANNELLI PORTA ATTREZZI E ACCESSORI WALL TOOLS GRID AND ACCESSORIES

GRIGLIA PORTA ATTREZZI
WALL TOOLS GRID



Codice / Item Dimensioni/Dimensions
MF-PA2000-01 200x81x5 cm



Codice / Item Dimensioni/Dimensions
MF-PA1620-01 162x81x5 cm



Codice / Item Dimensioni/Dimensions
MF-PA1000-01 100x81x5 cm



Codice / Item Dimensioni/Dimensions
MF-BL KGP1000 100x70.5x5.5 cm
MF-BL KGP1620 162x70.5x5.5 cm
MF-BL KGP2000 200x70.5x5.5 cm

GRIGLIE PER
PENSILI
GRIDS FOR
CUPBOARDS

ARMADIO PORTA ATTREZZI CON
SERRANDA DI CHIUSURA A SERRATURA
TOOL TRAY WALL TOP CHEST WITH
PANEL AND LOCK



Codice / Item Dimensioni/Dimensions
MF-MA2000-01 200x100x20 cm

Codice / Item Dimensioni/Dimensions
MF-MA1620-01 162x100x20 cm



PENSILI
CUPBOARDS

Codice / Item Dimensioni/Dimensions
MF-BL M14 81x40x30 cm

Codice / Item Dimensioni/Dimensions
MF-BL M15 100x40x30 cm



Codice / Item Pensile ad angolo
MF-BL M17

Codice / Item Corner Cupboard
MF-BL M17

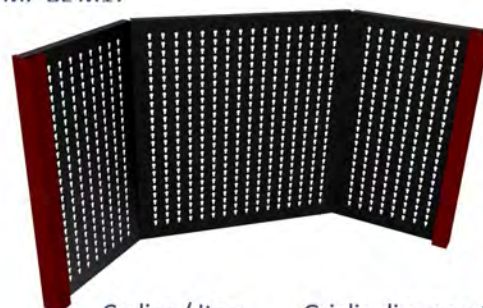

Codice / Item Griglia di supporto per
MF-BL KGP/A pensile ad angolo
Codice / Item Supporting wall grid for
MF-BL KGP/A corner cupboard

ANGOLI ED ACCESSORI MODOFLEX MODOFLEX CORNERS AND ACCESSORIES

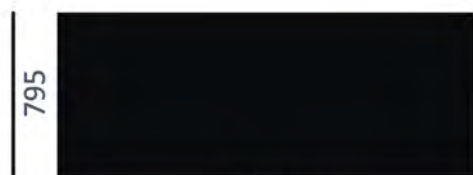

1995

Copertura gomma anti-olio
Oil-Resistant rubber cover



1610

Copertura gomma anti-olio
Oil-Resistant rubber cover



995

Copertura gomma anti-olio
Oil-Resistant rubber cover

Codice / Item	Dimens./Dimensions
MF-PG2000-01/03	1995x795x3mm
MF-PG2000-01	1995x795x6mm

Codice / Item	Dimens./Dimensions
MF-PG1620-01/03	1610x795x3mm
MF-PG1620-01	1610x795x6mm

Codice / Item	Dimens./Dimensions
MF-PG1000-01/03	995x795x3mm
MF-PG1000-01	995x795x6mm



Piano ad Angolo / *Corner Shelf*

Codice / Item	Dimensioni/Dimensions
MF-PANG-900	900x900 mm

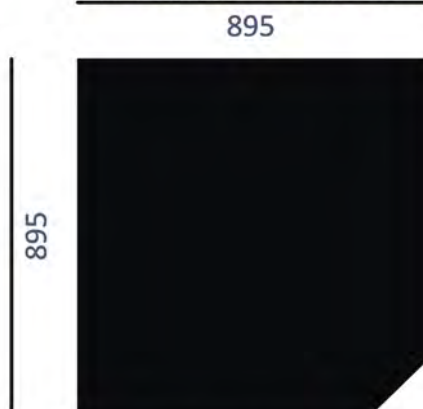

Copertura gomma anti-olio
per Piano Angolo
*Oil-Resistant rubber cover
for Corner Shelf*

Codice / Item	Dimensioni/Dimensions
MF-PGANG-01/03	895x895x3 mm
MF-PGANG-01	895x895x6 mm



Codice / Item	Dimensioni/Dimensions
MF-BL LED800	L=800 mm
MF-BL LED1000	L=1000 mm

Luci magnetiche a led bianco ghiaccio da applicare sotto ai pensili.
Magnetic ice white led lights to position under the cupboards.



Codice / Item Dimensioni/Dimensions
MF-GPPLAST-08 diam.30mm L=75mm

Confezione / Package
Pezzo Sing./Single piece



Codice / Item Dimensioni/Dimensions
MF-GPPLAST-04 diam.5mm L=40mm

Confezione / Package
box 100 pcs



Codice / Item Dimensioni/Dimensions
MF-GPPLAST-07 diam.5mm L=50mm

Altezza/Height Confezione / Package
45 mm box 100 pcs



Codice / Item Dimensioni/Dimensions
MF-GPPLAST-05 diam.5mm L=35mm

Occhiello/Eye Confezione / Package
8 mm box 100 pcs



Codice / Item Dimensioni/Dimensions
MF-GPPLAST-06 diam.5mm L=38mm

Occhiello/Eye Confezione / Package
14 mm box 100 pcs



Codice / Item Dimensioni/Dimensions
MF-GPPLAST-03 diam.5mm L=25mm

Confezione /Package
box 100 pcs



Codice / Item Dimensioni/Dimensions
MF-GPPLAST-02 diam.5mm L=55mm

Confezione /Package
box 100 pcs



Codice / Item Dimensioni/Dimensions
MF-GPPLAST-01 diam.5mm L=35mm

Confezione /Package
box 200 pcs



Codice / Item Dim./Dimens.
MF-GPMETAL01/P diam.5mm L=100mm
box 100 PCS
MF-GPMETAL02/P diam.5mm L=150mm
box 50 PCS
MF-GPMETAL03/P diam.5mm l=200mm
box 50 PCS



Codice / Item Dimensioni/Dimensions
MF-BPPUNTE-01 95x65x35mm



Codice / Item Dimensioni/Dimensions
MF-VATRASP-02 125x125x65mm



Codice / Item Dimensioni/Dimensions
MF-VATRASP-01 105x105x45mm

SET ATTREZZI PER CASSETTIERE M1-M2-CB SU PREFORMATO
M1-M2-CB DRAWERS MODULES SET OF TOOLS



Set 142 pezzi chiavi a cricchetto
Set 142 pcs flank sockets
Codice / Item 214201
Mis. / Size 1/4"-3/8"



Set 93 pz. chiavi a cricc. SAE
Set 93 pcs SAE flank sockets
Codice / Item 309301 v.02
Mis. / Size 1/4"-3/8"-1/2"

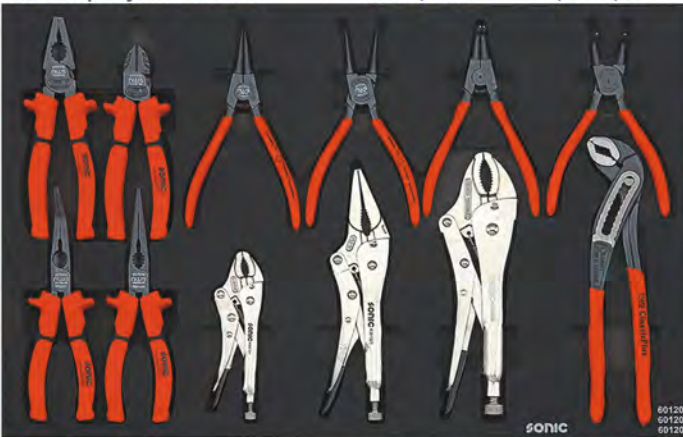

Set 12 pezzi pinze
Set 12 pcs pliers
Codice / Item 601207



Set 21 pz. cacc.bussola/viti esag.
Set 21 pcs socket scr./hex grip key
Codice / Item 602104



Set 23 pz. mart./pinze/scalp./lime
Set 23 pcs hamm./plier/chisel/file
Codice / Item 602302 v.4

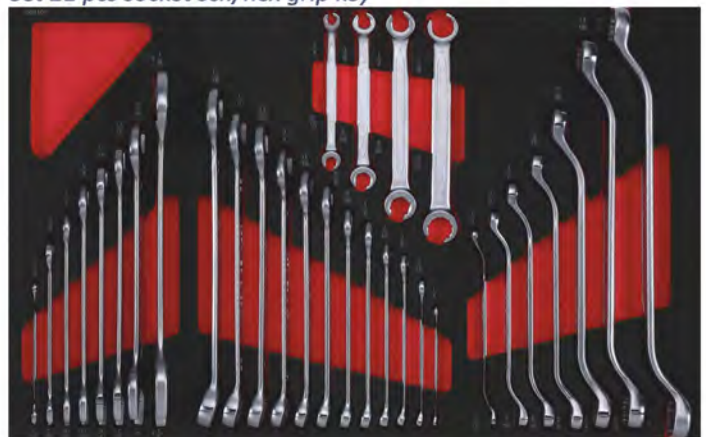

Set 31 pz. chiavi SAE
Set 31 pcs SAE wrenches
Codice / Item 603101



Set 35 pz. cacciaviti/brugole
Set 35 pcs screwdrivers
Codice / Item 603506



Set 40 pz. chiavi
Set 40 pcs wrenches
Codice / Item 604002 v.2



Scaffale per pneumatici appositamente studiato per lo stoccaggio delle gomme per moto e scooters. I ripiani possono essere regolati in 13 diverse posizioni.

Tyres shelf specifically designed for the storage of motorcycle and mopeds tyres. The shelves can be adjusted in 13 different positions.

Codice / Item Dimensioni / Dimensions
MF-SP1500-01 1500x2350x350 mm



MF-SP1500-01



MF-PD2000-01

Parete divisoria attrezzata con pannello porta attrezzi a due facce e due ripiani. Montato su ruote girevoli.

Double sided tool tray wall with shelves. Mounted on pivoting castors.

Codice / Item Dimensioni / Dimensions
MF-PD2000-01 2000x1940x350 mm



Carrello da officina con 3 ripiani
Workshop trolley with 3 shelves

Codice / Item Dimensioni / Dimensions
MF-CO670-01 670x875x370 mm



Carrello da officina con 3 ripiani
Workshop trolley with 3 shelves

Codice / Item Dimensioni / Dimensions
MF-CO900-01 900x1100x650 mm

VASCA LAVAPEZZI CABINATA CABIN PARTS WASHER

Pompa ad alta pressione da 160bar con pistola e selettore di azionamento sul pannello frontale.

Capacità operativa 9L/minuto.

Selettore di azionamento pompa a pressione per lavaggio con pennello.

Struttura esterna in ferro e vasca interna in acciaio INOX.

High pressure 160bar pump supplied with a washing gun operating through a front panel switch.

Operative capacity 9L/minute.



Brush cleaning operating with a low pressure pump with activation by a front panel switch.

External chassis made of iron and internal parts made of stainless steel.

Codice / Item MF-PW1000-01

Dimensioni/
Dimensions 103x70x119 cm

Dimensioni Interne
Internal Dimensions 600x800 mm

Capacità vasca
Tank Capacity 80 L

Peso / Weight 100 kg

MODULI SPECIALI ED ACCESSORI BANCHI
SPECIAL MODULES & WORKBENCHES ACCESSORIES

Codice / Item MF-WOT



Modulo con vasca in acciaio INOX per il contenimento di olio esausto, dotato di pompa di aspirazione per lo svuotamento della vasca..
Fornita di pulsante a pressione di azionamento.

*Workshop module with stainless steel basin for exhausted oil.
Equipped with a suction pump to connect to the main waste oil container.
Supplied of a push button for the pump activation.*

Modulo con vasca in acciaio INOX per lo svuotamento dell'olio delle forcelle. Dotato di sportello per l'inserimento del contenitore in cui l'olio defluisce per gravità.

*Workshop module with stainless steel basin for the exhausted fork oil.
Equipped with a side door for the receiving tank in which the oil drains for gravity.*

PUNTO ATTREZZATO con presa Schuko (tedesca) presa LAN per computer e uno slot vuoto a scelta. Sistema di apertura POP-UP a scomparsa inseribile come optional su tutti i nostri banchi, anche con comando sollevatori..
RETRACTABLE POP-UP Schuko type power socket outlet with LAN network and free slot to be installed as optional on all our workbenches. Can be provided of up & down buttons to control the lift.



Codice-Item

MF-BL/POP

Dimensioni-Dimensions

120x142.5x5mm

Codice / Item MF-FOB



BANCO MANUTENZIONE SOSPENSIONI SUSPENSION REPAIR WORKBENCH



Codice / Item	MF-SB 2300
Dimensioni/ Dimensions	230x80x90 cm
Peso / Weight	350 kg

Banco professionale per la manutenzione e riparazione delle sospensioni, con piani di lavoro, griglie e vasche di scolo olio in acciaio inox. E' fornito di una cassetteria a 5 cassetti e di un modulo per la sistemazione delle cartucce di ricambio per gli steli. Fornito con 2 morse incluse e con 6 piedini regolabili.

Professional suspension bench, with tabletop, grids and oil drain basins all made in stainless steel. This product features a 5 drawer cabinet and a module for storing the spare fork cartridges. It is supplied with 2 vices included and 6 adjustable foot.

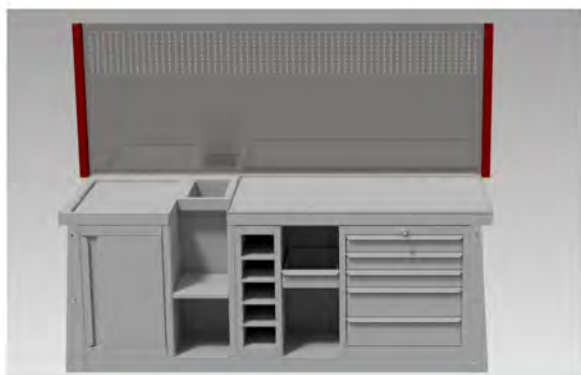

Griglia in acciaio inox con piantoni di sostegno da posizionare in corrispondenza del banco sospensioni per poter appendere gli steli smontati. Utilizzando l'apposita griglia da 10cm fra il banco ed il muro si raccolgono gli eventuali liquidi.

Stainless steel wall grid board with side supports to be positioned at the workbench wall and hang the disassembled forks and suspension using the special 10cm wide grid included in the workbench, to drain the eventual liquids.

Codice / Item	MF-BL KGP/SS
Dimensioni/ Dimensions	230x90 cm
Peso / Weight	15 kg



courtesy of Black Flag Racing

Vasca inox con griglia
removibile
*St. Steel basin with
removable grid cover*

Pozzetto in acciaio inox
per pezzi alti
*St. Steel deep basin for
long parts*

Piano in acciaio inox per
lo smontaggio delle
forcelle e delle sospensioni
*St. Steel tabletop for the
disassembling of forks and
suspension*

Cassettiera a 5
cassetti per attrezzi
*5 drawers cabinet
for tools*



Sportello per accesso al
contenitore di raccolta
olio (non incluso)
*Access door to the waste
oil container (not included)*

Attacco morsa
basso per lavori
sulla parte alta
della sospensione
*Low vice fitting
for operations in
the high side of
the suspension*

Vano di servizio
per componenti
*Components
open shelf*

Cassetto scorrevole per
vasca in plastica(non incl.)
per la raccolta dell'olio
durante lo smontaggio
dei pezzi
*Sliding drawer for a plastic
pan (not incl.) for the
containment of the oil during
the parts disassembling*

Ripiani per le
cartucce nuove
degli steli
*Trays for the spare
fork cartridges*

Griglia con larghezza di 10 centimetri per
la raccolta di liquidi durante l'asciugatura
da usare in combinazione alla griglia in
acciaio inox da muro.

*10 cm wide stainless steel grid for the
drain of liquids of forks repaired. To be
use together the stainless steel
wall grid board.*



appt RACING TEAM GREY



a
NG
INI

ZACCARATE
Abtorex
LI BERNER
RCR Z
F&B
SAGTUBI
PAN

sky O
aprilia
Aprilia
Xperia
MARSH
aprilia
sky Q
Unibat
aprilia



RACING EQUIPMENT



MRA



Codice / Item	MRA
Larghezza / Width	565 mm
Altezza / Height	900 mm
Lunghezza / Length	1688 mm
Peso / Weight	83 kg

Frutto della lunga collaborazione fra Bike-Lift Europe ed il Team GRESINI nasce l' MRA in alluminio, creato per ottimizzare gli interventi nel box e minimizzare i costi di trasporto nelle trasferte internazionali della MotoGP.

Il modulo MRA ha un peso pari ad 1/3 di un modulo tradizionale, mantenendo le performances di robustezza e praticità necessarie ad un attrezzo a cui è richiesto ogni giorno di dimostrarsi professionale ed affidabile al 100%.

Created by the long cooperation between Bike-lift Europe and the GRESINI Team, the MRA has been developed to optimize the paddock operations and minimize the freight costs for the worldwide races of the MotoGP Championship.

The MRA module weighs 1/3 of a traditional one but offers the same performances of strength and practical use required by a tool that has to prove every day to be 100% professional and reliable.

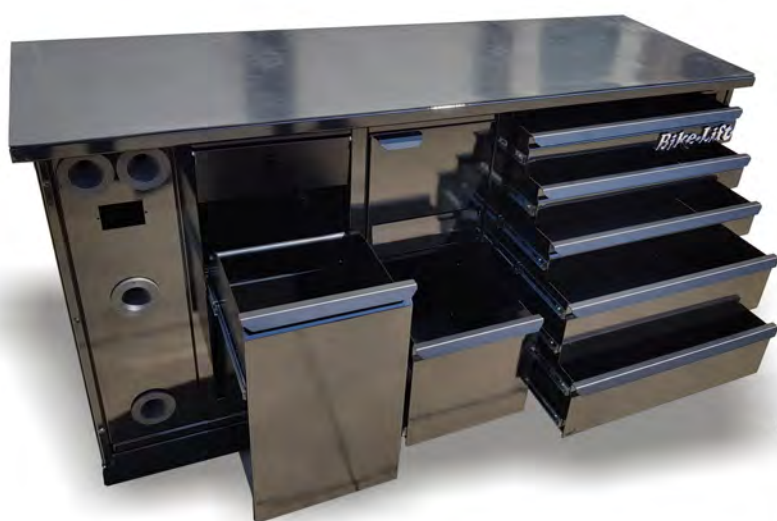

100% ALLUMINIO

100% ALUMINIUM



Il modulo MRA può essere costruito con colori a scelta del TEAM ed è componibile con moduli diversi da quelli in foto.

The MRA module can be built with colors chosen by the TEAM and it can be assembled with other modules than those in the pictures.



MRA-MXGP



Codice / Item	MRA-MXGP
Larghezza / Width	565 mm
Altezza / Height	900 mm
Lunghezza / Length	1868 mm
Peso / Weight	88 kg

Versione del modulo racing MRA con un modulo con sportello (M3) anziché il pannello servizi.

Version of the racing module MRA featuring a module with door and shelf (M3)instead the services panel.

MRF



Codice / Item	MRF
Larghezza / Width	565 mm
Altezza / Height	900 mm
Lunghezza / Length	1688 mm
Peso / Weight	249 kg

Stesse caratteristiche costruttive del modello MRA ma costruito con lamiera di ferro anziché alluminio.

Pensato per i Team che non fanno gare internazionali e che quindi non devono sopportare costi di trasporto gravosi.

Anche questo modello può essere con i colori decisi dal Team e con moduli anche diversi da quelli in foto.

Same technical characteristics of the MRA model but built in metal plate instead of aluminium.

Developed for those Teams that do not compete internationally and don't need to save on weight for freight costs. This model can also be painted/coated at Team's choice and with modules different than those in the pictures.



photo courtesy BLACKFLAG Motorsport



Codice / Item	MRS-MOTO3
Larghezza / Width	565 mm
Altezza / Height	900 mm
Lunghezza / Length	1258 mm
Peso / Weight	138 kg

Scrivania da paddock AL-DK non inclusa
Paddock writing-desk AL-DK not included

L' MRS-MOTO3 è un altro dei numerosi prodotti sviluppati in collaborazione con il GRESINI Racing Team. Modulo dalle dimensioni più contenute rispetto ai precedenti, dal momento che deve posizionarsi ed essere operativo in spazi minori all'interno del paddock. Costruito in lamiera di ferro è molto compatto e modulabile sia in termini di colorazione che di servizi al suo interno.

The MRS-MOTO3 is another of the many products developed with the GRESINI Racing Team. It is a module featuring smaller sizes in comparison with the previous models, because it has to be positioned and be operative in smaller areas inside the paddock. Built with iron plate it is very compact and can be modulable in terms of color and services inside it.



photo courtesy GRESINI Junior Team

AL-BN



Codice / Item	AL-BN
Larghezza / Width	60 cm
Altezza / Height	60 cm
Lunghezza / Length	200 cm
Peso / Weight	25 kg

Panca in alluminio pieghevole con rampa
Folding aluminium bench with ramp



photo courtesy GRESINI Junior Team



photo courtesy SIC58 Racing Team



Tappeto di protezione optional.
Rif. pagina 42
Optional cover mat. See page 42.

AL-DK

Codice / Item	AL-DK
Larghezza / Width	70 cm
Altezza / Height	69 cm
Lunghezza / Length	150 cm
Peso / Weight	25 kg

Scrivania da paddock interamente in alluminio.
Dotata di gambe pieghevoli per il trasporto.
Completamente personalizzabile.

*Paddock writing-desk made in full aluminium.
Equipped with folding legs for the easy transport
and storage. Fully customizable.*



AL-WT

Codice / Item	AL-WT
Larghezza / Width	55 cm
Altezza / Height	148 cm
Lunghezza / Length	140 cm

Porta pneumatici da Pitlane
Pitlane alu wheel trolley



MF-SR

Codice / Item	MF-SR
Peso / Weight	16 kg

Sedia racing da paddock
Racing char for paddock



FPS-25 HIGH

Codice / Item	FPS-25 HIGH
Larghezza / Width	40 cm
Altezza / Height	810 cm
Lunghezza / Length	20 cm

Candelabri per pedane racing
Footpeg racing stand

RS-KALEX MOTO 2

Codice / Item	RS-KALEX
---------------	----------

Cavalletto posteriore per telaio KALEX moto 2
Rear stand for KALEX moto 2 frame



RS-MOTO 3

Codice / Item	RS-MOTO 3
---------------	-----------

Cavalletto posteriore per MOTO 3
Rear stand for Moto 3



Codice / Item	SM-19
---------------	-------

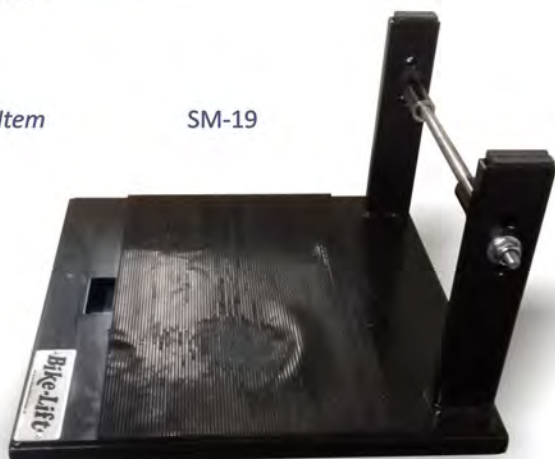

SUPPORTO MOTORE

Supporto per trasporto e stoccaggio motori con adattatori universali.
Support for the transport and storage of engines, with universal pin included.



XXI RACING



Cavalletto posteriore in edizione limitata sviluppato in collaborazione con il GRESINI Racing Team MotoGP, costruito interamente in alluminio.

Limited edition rear stand, developed in cooperation with the MotoGP GRESINI Racing Team, in full aluminium.

Codice / Item	XXI GR
Larghezza / Width	35.5 cm
Peso / Weight	4.2 kg
Lunghezza / Length	63 cm
Altezza / Height	34 cm

NON montare sulla moto quando il cavalletto è in uso.
DO NOT ride the motorcycle when the stand is in use



CAVALLETTI Paddock STANDS



BLACK ICE

NON montare sulla moto quando il cavalletto è in uso.
DO NOT ride the motorcycle when the stand is in use



Supporto a cono
Underfork Adapter

Codice / Item BI-SC

Larghezza Max. / Max. Width 24 cm
Larghezza Min. / Min. Width 16 cm



Supporto a forchetta
V-Shaped Adapter

Codice / Item BI-SF

Larghezza Max. / Max. Width 36.5 cm
Larghezza Min. / Min. Width 29 cm



BLACK ICE RS cavalletto posteriore / rear stand

Codice / Item BI-RS

Larghezza / Width 52 cm

Peso / Weight 4.0 kg

Lunghezza / Length 67 cm

Altezza / Height 37 cm



BLACK ICE FS cavalletto anteriore / front stand

Codice / Item BI-FS

Larghezza / Width 41.5 cm

Peso / Weight 3.8 kg

Lunghezza / Length 68 cm

Altezza / Height 34 cm



Supporto in gomma
Rubber Adapter

Codice / Item BI-SG

Larghezza Max. / Max. Width 33.5 cm
Larghezza Min. / Min. Width 27 cm



Supporto a rullo per pinze radiali
Roller adapters for radial calipers

Codice / Item BI-SAP

Larghezza Max. / Max. Width 23.5 cm
Larghezza Min. / Min. Width 15.5 cm



Supporto in gomma piccolo
Small rubber Adapter

Codice / Item BI-SGS

Larghezza Max. / Max. Width 23.5 cm
Larghezza Min. / Min. Width 15.5 cm



Usare il cavalletto anteriore SOLO se già posizionato il cavalletto posteriore.
Use the front stand ONLY if the rear stand has been positioned first



PATENT
DESIGN

FRONT STANDS



Include
Included

Protezioni in gomma che hanno anche funzione di stabilizzare il cavalletto.
Protection pads that are also a mean to stabilize the stand.

NON montare sulla moto quando il cavalletto è in uso.
DO NOT ride the motorcycle when the stand is in use



FS-10



Usare il cavalletto anteriore **SOLO** se già posizionato il cavalletto posteriore.
Use the front stand **ONLY** if the rear stand has been positioned first



FS-9



COLORI STANDARD
FACTORY COLORS



RAL 3002



RAL 9005

E' possibile realizzare altri colori Ral su richiesta per lotti minimi di produzione, sia per il tubolare che per le ruote.
It is possible to produce other RAL colors on demand and for MOQ of production, both for the pipe and the wheel-tyre.

CODICE / ITEM SAG-10



Supporto in gomma
Rubber Adapter

Larghezza
Span
Max. 25cm
Min. 16cm

CODICE / ITEM SAC-10



Supporto a Cono
Underfork Adapter

Larghezza
Span
Max. 24.5cm
Min. 16cm

CODICE / ITEM SAP-10



Supporto a Rullo per Pinze Radiali
Roller Adapter
Larghezza
Span
Max. 23.5cm
Min. 15.5cm

CODICE / ITEM SAC-10/Y



Supporto a Cono
Underfork Adapter
Larghezza
Span
Max. 24.5cm
Min. 16cm

Inseriti rinforzati
Reinforced adapter head



CODICE / ITEM SAR-10



Supporto a Rullo
Roller Adapter
Larghezza
Span
Max. 24cm
Min. 15cm

FS-10 cavalletto anteriore / FS-10 front stand

Codice / Item FS-10



Larghezza / Width 43 cm
Peso / Weight 3.7 kg
Lunghezza / Length 67 cm
Altezza / Height 33 cm

FS-9 cavalletto anteriore / FS-9 front stand

Codice / Item BI-FS



Larghezza / Width 35 cm
Peso / Weight 3.0 kg
Lunghezza / Length 61 cm
Altezza / Height 32 cm

FRONT STANDS



NON montare sulla moto quando il cavalletto è in uso.
DO NOT ride the motorcycle when the stand is in use

Usare il cavalletto anteriore SOLO se già posizionato il cavalletto posteriore.
Use the front stand ONLY if the rear stand has been positioned first



FS-10/H

cavalletto alto per pinze radiali con supporti SBG-P
high stand for radial calipers with SBG-P adapters included



COLORI STANDARD
FACTORY COLORS



RAL 3002



RAL 9005

E' possibile realizzare altri colori Ral su richiesta per lotti minimi di produzione, sia per il tubolare che per le ruote.
It is possible to produce other RAL colors on demand and for MOQ of production, both for the pipe and the wheel-tyre.

FS-10/H-S

senza supporti / without adapters



FS-10/H cavalletto anteriore / FS-10/H front stand

Codice / Item	FS-10/H
Larghezza / Width	36 cm
Peso / Weight	3.8 kg
Lunghezza / Length	62 cm
Altezza / Height	35 cm
Supporti inclusi	SBG-10/P

CODICE / ITEM SAP-10



Supporto a Rullo per Pinze Radiali
Roller Adapter
Larghezza Span
Max.23.5cm
Min. 15.5cm

Inseri rinforzati Reinforced adapter head



FS-10/H cavalletto anteriore / FS-10/H-S front stand

Codice / Item	FS-10/H-S
Larghezza / Width	36 cm
Peso / Weight	3.8 kg
Lunghezza / Length	62 cm
Altezza / Height	35 cm
Supporti inclusi	SBG-10/P

Include/Included



Protezioni in gomma che hanno anche funzione di stabilizzare il cavalletto.
Protection pads that are also a mean to stabilize the stand.

FLUO & COLORED COLLECTION



REAR STANDS



REAR STANDS



Bike-Lift
EUROPE



Include/Included

Protezioni in gomma che hanno anche funzione di stabilizzare il cavalletto.
Protection pads that are also a mean to stabilize the stand.

RS-17

senza adattatori
without adapters



NON montare sulla moto quando il cavalletto è in uso.
DO NOT ride the motorcycle when the stand is in use

RS-17/L

con supporti a forchetta inclusi/
with V-Shaped adapters included



RS-17 cavalletto posteriore / RS-17 rear stand

Codice / Item	RS-17
Larghezza / Width	54 cm
Peso / Weight	3.9 kg
Lunghezza / Length	67 cm
Altezza / Height	34 cm

RS-17/L cavalletto posteriore basso / RS-17/L low rear stand

Codice / Item	RS-17/L
Larghezza / Width	54 cm
Peso / Weight	3.8 kg
Lunghezza / Length	70 cm
Altezza / Height	31 cm
Supporti inclusi Adapters included	SAF-10



COLORI STANDARD
FACTORY COLORS

RAL 3002



RAL 9005



E' possibile realizzare altri colori Ral su richiesta per lotti minimi di produzione, sia per il tubolare che per le ruote.
It is possible to produce other RAL colors on demand and for MOQ of production, both for the pipe and the wheel-tyre.

REAR STANDS



BLUE

BLACK

RED

TITANIUM

M6 M8 M10

Nottolini in alluminio / Aluminium Bobbins

Confezione con viti incluse
Packaging with screws included



Nottolini in alluminio KTM
Aluminium Bobbins for KTM

Codice / Item NA-M10/K



Codice / Item	Colore/Color	Modello/Model
NA-M6/R	Rosso/Red	YAMAHA/APRILIA/TRIUMPH
NA-M6/B	Blu/Blue	YAMAHA/APRILIA/TRIUMPH
NA-M6/T	Titanio/Titanium	YAMAHA/APRILIA/TRIUMPH
NA-M6/N	Nero/Black	YAMAHA/APRILIA/TRIUMPH
NA-M8/R	Rosso/Red	SUZUKI/HONDA/DUCATI
NA-M8/B	Blu/Blue	SUZUKI/HONDA/DUCATI
NA-M8/T	Titanio/Titanium	SUZUKI/HONDA/DUCATI
NA-M8/N	Nero/Black	SUZUKI/HONDA/DUCATI
NA-M10/R	Rosso/Red	KAWASAKI
NA-M10/B	Blu/Blue	KAWASAKI
NA-M10/T	Titanio/Titanium	KAWASAKI
NA-M10/N	Nero/Black	KAWASAKI

Espositore 24 confezioni
Display for 24 boxes



Incluse/
Included



Protezioni in gomma che hanno anche funzione di stabilizzare il cavalletto.
Protection pads that are also a mean to stabilize the stand.

NON montare sulla moto quando il cavalletto è in uso.
DO NOT ride the motorcycle when the stand is in use



Codice / Item SAF-10
Supporto a forchetta
V-Shape Adapter
Larghezza/Width
Max. 37 cm
Min. 30 cm



Codice / Item SBG-10
Supporto in Gomma
Rubber Adapter
Larghezza/Width
Max. 34.5 cm
Min. 27.5 cm

RS-17/XL cavalletto post. Extra Basso
RS-17/XL Extra Low rear stand

Codice / Item RS-17/XL

Larghezza / Width	58 cm
Peso / Weight	3.7 kg
Lunghezza / Length	70.5 cm
Altezza / Height	28.5 cm
Supporti Inclusi Supports Included	SAF-10



RS-17/XL

Supporti a forchetta inclusi
V-Shaped adapters included



REAR STANDS



RS-17/TB

RS-17/Ducati Scrambler rear stand
RS-17/ Ducati Scrambler rear stand

Codice / Item RS-17/SCRAMBLER



Larghezza / Width 55 cm
Peso / Weight 3.8 kg
Lunghezza / Length 67 cm
Altezza / Height 30 cm
Supporti inclusi
Adapters included



Include/Included
Protezioni in gomma che hanno anche funzione di stabilizzare il cavalletto.
Protection pads that are also a mean to stabilize the stand.



RS-17/ Scrambler



NON montare sulla moto quando il cavalletto è in uso.
DO NOT ride the motorcycle when the stand is in use



RS-17/TB cavalletto posteriore
Triumph Bonneville
RS-17/TB rear stand for
Triumph Bonneville

Codice / Item	RS-17/TB
Larghezza / Width	43 cm
Peso / Weight	2.8 kg
Lunghezza / Length	62 cm
Altezza / Height	36.5 cm

COLORI STANDARD
FACTORY COLORS

RAL 3002



RAL 9005



E' possibile realizzare altri colori Ral su richiesta per lotti minimi di produzione, sia per il tubolare che per le ruote.
It is possible to produce other RAL colors on demand and for MOQ of production, both for the pipe and the wheel-tyre.



REAR STANDS

RS-18/F



Include/Included

Protezioni in gomma che hanno anche funzione di stabilizzare il cavalletto.
Protection pads that are also a mean to stabilize the stand.



Codice / Item RS-18/F

Cavalletto Posteriore Fisso
Fixed Rear Stand

Larghezza / Width	41 cm
Peso / Weight	3.9 kg
Lunghezza / Length	63 cm
Altezza / Height	37.5 cm
Supporti Gomma Inclusi	
<i>Rubber Supports Included</i>	

COLORI STANDARD
FACTORY COLORS



E' possibile realizzare altri colori Ral su richiesta per lotti minimi di produzione, sia per il tubolare che per le ruote.

It is possible to produce other RAL colors on demand and for MOQ of production, both for the pipe and the wheel-tyre.

NON montare sulla moto quando il cavalletto è in uso.
DO NOT ride the motorcycle when the stand is in use



RS-18/G



Codice / Item RS-18/G

Cavalletto Posteriore Fisso
Fixed Rear Stand



Larghezza / Width	41 cm
Peso / Weight	3.9 kg
Lunghezza / Length	60 cm
Altezza / Height	31 cm
Supporti Forchetta Inclusi	
<i>V-Shape Supports Included</i>	

REAR STANDS



FPS-25



FPS-25 cavalletto posteriore
pedane racing regolabile
*FPS-25 adjustable rear stand
for footpegs*



**NON montare sulla moto quando
il cavalletto è in uso.
DO NOT ride the motorcycle when
the stand is in use**

Codice / Item	FPS-25
Larghezza / Width	40 cm
Peso / Weight	3.0 kg
Lunghezza / Length	20 cm
Altezza Max. Max Height	43 cm
Altezza Min. Min. Height	37 cm

COLORI STANDARD
FACTORY COLORS

RAL 3002



RAL 9005



E' possibile realizzare altri colori Ral su richiesta
per lotti minimi di produzione, sia per il
tubolare che per le ruote.

It is possible to produce other RAL colors on
demand and for MOQ of production, both
for the pipe and the wheel-tyre.

RE-M Easy Mover rear stand
RE-M Easy Mover rear stand

Codice / Item RE-M

Larghezza / Width	64 cm
Peso / Weight	8.2 kg
Lunghezza / Length	73 cm
Altezza / Height	32.5 cm

Utilizzabile solo con adattatori SAF-10
Recommended with SAF-10 adapters only



RE-M

REAR STANDS

Include
Included



Protezioni in gomma che hanno anche funzione di stabilizzare il cavalletto.
Protection pads that are also a mean to stabilize the stand.

Codice / Item RS-S
Cavalletto Posteriore
per Scooters
Mopeds rear stand



Larghezza / Width 54 cm
Peso / Weight 3.5 kg
Lunghezza / Length 57 cm
Altezza / Height 33 cm
Supporti Non Inclusi
Adapters not included



COLORI STANDARD
FACTORY COLORS

RAL 3002



RAL 9005



RS-S

NON montare sulla moto quando
il cavalletto è in uso.
DO NOT ride the motorcycle when
the stand is in use



Codice / Item RS-S-MI
Adattatore Minarelli
Minarelli Adapter

Codice / Item RS-S-PEU
Adattatore Peugeot
Peugeot Adapter



Codice / Item RS-S-PIA
Adattatore Piaggio
Piaggio Adapter



REAR STANDS



RS-16

RS-16 cavalletto posteriore monobraccio
RS-16 Single Swing arm rear stand

Codice / Item	RS-16
Larghezza / Width	55 cm
Peso / Weight	5.6 kg
Lunghezza / Length	70 cm
Altezza / Height	42.5 cm

Perni non inclusi
Pins not included

COLORI STANDARD
FACTORY COLORS

RAL 3002



RAL 9005



NON montare sulla moto quando il cavalletto è in uso.
DO NOT ride the motorcycle when the stand is in use

E' possibile realizzare altri colori Ral su richiesta per lotti minimi di produzione, sia per il tubolare che per le ruote.

It is possible to produce other RAL colors on demand and for MOQ of production, both for the pipe and the wheel-tyre.

Perni / Pins



Codice / Item *PMB-1200K*
Modello / Model *BMW*
Diametro/Diameter *53mm*



Codice / Item *PMB-CB08-18*
Modello / Model *Honda CBR>2018*
Diametro/Diameter *18.1mm*



Codice / Item *PMD-98/40*
Modello / Model *DUCATI*
Diametro/Diameter *40.5 mm*



Codice / Item *PMD-01*
Modello / Model *DUCATI*
Diametro/Diameter *21.8/25.9 mm*



Codice / Item *PMH-01*
Modello / Model *Honda*
Diametro/Diameter *28.7 mm*



Codice / Item *PMH-CB08*
Modello / Model *Honda1000 CBR<2018*
Diametro/Diameter *28.25 mm*

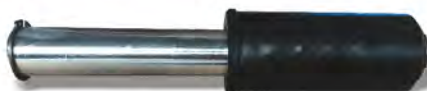

Codice / Item *PMM-01*
Modello / Model *MV AGUSTA
DUCATI
BMW*



Codice / Item *PMT-01*
Modello / Model *Triumph-KTM S.Duke*
Diametro/Diameter *27.5 mm*

Include
Included



Protezioni in gomma che hanno anche funzione di stabilizzare il cavalletto.
Protection pads that are also a mean to stabilize the stand.

Diametro/Diameter *42.5 mm*

REAR STANDS

NON montare sulla moto quando il cavalletto è in uso.
DO NOT ride the motorcycle when the stand is in use



Incluse
Included



Protezioni in gomma che hanno anche funzione di stabilizzare il cavalletto. Protection pads that are also a mean to stabilize the stand.

RS-16/R



Codice / Item RS-16/R
Cavalletto Posteriore
Monobraccio Destro
Rear Single Swing Arm
right side



Larghezza / Width 55 cm
Peso / Weight 5.6 kg
Lunghezza / Length 70 cm
Altezza / Height 42.5 cm
Perni Non Inclusi
Pins not included

COLORI STANDARD
FACTORY COLORS

RAL 3002



RAL 9005



Codice / Item PMD-01/R
Modello / Model DUCATI
Diametro/Diameter 29.8 mm



Codice / Item PMB-650
Modello / Model BMW F650CS-F800-S/ST
Diametro/Diameter 30.0 mm



Codice / Item PMB-1200
Modello / Model BMW R1200 GS
Diametro/Diameter 51 mm



Codice / Item PMB-1200K
Modello / Model BMW
Diametro/Diameter 53 mm

CENTER STANDS



CS-24N

COLORI STANDARD
FACTORY COLORS

RAL 9005



E' possibile realizzare altri colori Ral su richiesta per lotti minimi di produzione, sia per il tubolare che per le ruote.

It is possible to produce other RAL colors on demand and for MOQ of production, both for the pipe and the wheel-tyre.

CS-24N cavalletto centrale
CS-24N Central Stand



Codice / Item CS-24/N

Larghezza / Width 56 cm

Peso / Weight 5.2 kg

Lunghezza / Length 48 cm

Altezza / Height 57 cm

Perni non inclusi
Pins not included

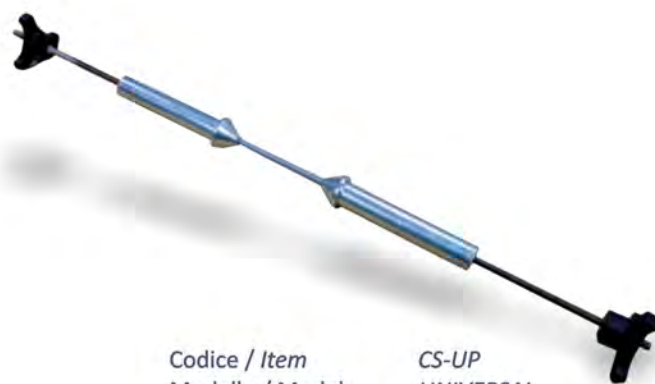

Codice / Item
Modello / Model

CS-UP
UNIVERSAL



Codice / Item CS-VFR
Modello / Model HONDA VFR 1200



NON montare sulla moto quando il cavalletto è in uso.
DO NOT ride the motorcycle when the stand is in use

CENTRAL STANDS



Codice / Item MCL-30

Larghezza / Width	25 cm
Altezza Max/Max Height	35 cm
Altezza Min./Min. Height	8.5 cm
Lunghezza/Length	40 cm
Portata Max/Max Load	500 kg
Azionamento Manuale Manual Action	

MCL-20



Codice / Item MCL-20

Larghezza / Width	15 cm
Altezza Max/Max Height	35 cm
Altezza Min./Min. Height	8.5 cm
Lunghezza/Length	40 cm
Portata Max/Max Load	500 kg
Azionamento Manuale Manual Action	

Supporti opzionali utilizzabili solo con il modello MCL-20 necessari quando non è possibile alzare la moto centralmente e bisogna quindi lavorare direttamente sulla parte inferiore del telaio.

Optional adapters only for MCL-20, to be used when it is not possible to lift the vehicle by its centre and so it is necessary to work directly on the bottom part of the frame.

Codice - Item

MCL-03A



MCL-30

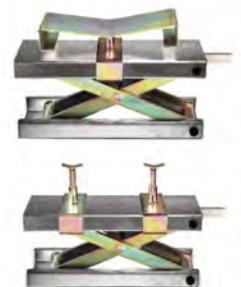

MCL-03A



WARNING

- I** NON UTILIZZARE MAI CHIAVI AD IMPULSO. POTREBBERO DANNEGGIARE LA VITE ED IL CUSCINETTO.
- USA GB** NEVER USE IMPACT WRENCHES AS THEY WOULD DAMAGE THE THREADS AND BEARINGS.
- F** NE JAMAIS UTILISER DE CLES A CHOC. ELLES POURRAIENT ENDOMMAGER LA VIS ET LE COUSSINET A BILLES.
- D** BENUTZEN SIE NIEMALS SCHLAGSCHRAUBEN MIT DRUCKLUFTANTRIEB ZUR BETÄTIGUNG. SIE KÖNNTEN DIE SPINDEL ODER DAS KUGELLAGER BESCHÄDIGEN.



**NON montare sulla moto quando il cavalletto è in uso.
DO NOT ride the motorcycle when the stand is in use**



DANGER

ASSICURARE LA MOTO CON CINGHIE DI SICUREZZA

FASTEN THE MOTORCYCLE WITH TIE DOWN

CENTER STANDS



Versione Quad e ATV
Quad & ATV Model

Versione Custom & Cruiser
Custom & Cruiser Model



Codice / Item	CFL-500
Larghezza / Width	38 cm
Portata Max./Max Load	500 kg
Azionamento/Action	pompa pedale foot pump
Altezza max./Max. Height	45 cm
Altezza min./Min. Height	11 cm
Posiz. Sicura/ Safety locks	3

Codice / Item	CFL-500/Q
Larghezza / Width	38 cm
Portata Max./Max Load	500 kg
Azionamento/Action	pompa pedale foot pump
Altezza max./Max. Height	55 cm
Altezza min./Min. Height	21 cm
Posiz. Sicura/ Safety locks	3





CENTRAL STANDS



Codice / Item	HXL-160
Larghezza / Width	33X45 cm
Portata Max./Max Load	160 kg
Azionamento/Action	pompa pedale foot pump
Altezza max./Max. Height	89 cm
Altezza min./Min. Height	39 cm
Molle Sicur./ Safety Hooks	2



Utilizzare sempre la sicura meccanica dopo aver sollevato la moto sul cavalletto HXL, oltre ai due ganci di sicurezza.

Always use the mechanical safety after the motorcycle has been lift onto the HXL central stand. Use as well the two safety hooks.

PADDOCK STANDS



WP-400

Piattaforma di Parcheggio
Wheel Parking Platform

Codice / Item	WP-400
Larghezza / Width	46.8 cm
Peso / Weight	8.0 kg
Lunghezza / Length	51 cm
Altezza / Height	5.9 cm
Portata / Max Load	400 kg

Codice / Item	SE-400
Larghezza / Width	14 cm
Peso / Weight	6.0 kg
Lunghezza / Length	86.5 cm
Altezza / Height	6.5 cm
Portata / Max Load	400 kg



SE-400

Estensione cavalletto laterale
Extension for side stand



Codice / Item	RS-Q-400
Larghezza / Width	50 cm
Peso / Weight	4.2 kg
Lunghezza / Length	65 cm
Altezza / Height	36 cm



RS-Q

Cavalletto per Quad
Rear stand for Quad

ERGAL STANDS



NON montare sulla moto quando
il cavalletto è in uso.
DO NOT ride the motorcycle when
the stand is in use



RS-17/E

Codice / Item RS-17/E
Cavalletto Posteriore
Ergal con supporti
Ergal rear stand with
V-shape support

Larghezza / Width	54 cm
Peso / Weight	2.0 kg
Lunghezza / Length	67 cm
Altezza / Height	34 cm
Perni Inclusi Pins included	



Include/Included

Protezioni in gomma che hanno anche funzione di stabilizzare il cavalletto.
Protection pads that are also a mean to stabilize the stand.



Larghezza/Width
Max 37 cm
Min. 30 cm

Codice / Item FS-17/E
Cavalletto Anteriore Ergal
con supporti inclusi
Ergal front stand with
underfork support

Larghezza / Width	43 cm
Peso / Weight	1.9 kg
Lunghezza / Length	67 cm
Altezza / Height	33 cm
Adattatori Inclusi Adapters included	



Larghezza/Width
Max 24.5 cm
Min. 16 cm

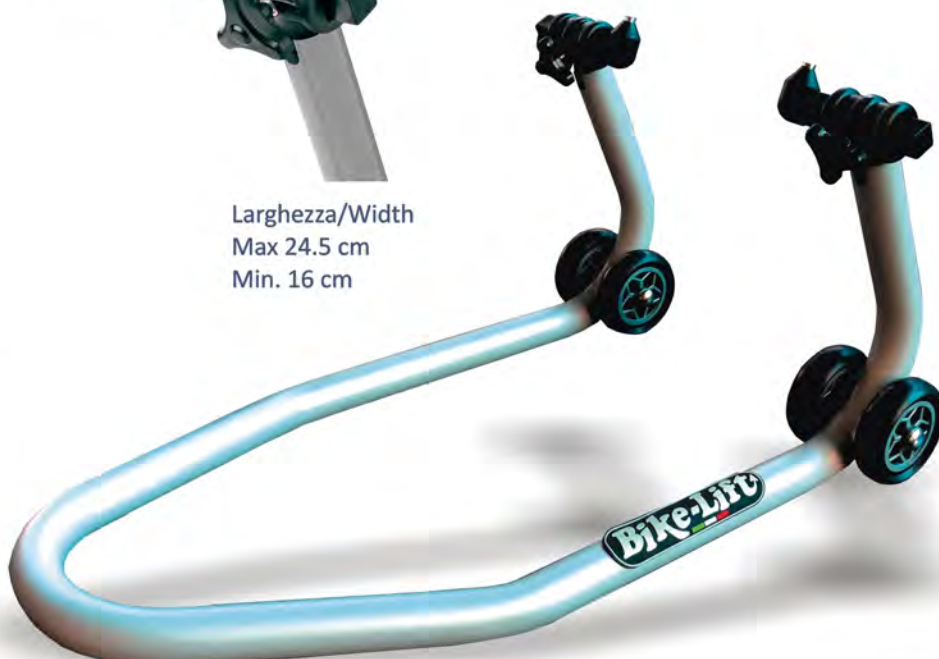

FS-17/E

HEADSTOCK STANDS



FS-11



Include/Included

Protezioni in gomma che hanno anche funzione di stabilizzare il cavalletto.
Protection pads that are also a mean to stabilize the stand.



FS-11 cavalletto sottocanotto
FS-11 headstock stand

Codice / Item	FS-11
Larghezza / Width	48 cm
Peso / Weight	7.1 kg
Lunghezza / Length	63 cm
Altezza max /Max Height	82 cm
Altezza min / Min. Height	65 cm

COLORI STANDARD
FACTORY COLORS

RAL 3002



RAL 9005



PERNI / PINS



Ø13 Ø15 Ø17 Ø18 Ø20 Ø23 Ø27

Il cavalletto FS-11 è disponibile in 2 versioni, una con il kit completo di 7 perni oppure con un solo perno a scelta del cliente. I codici sono :

FS-11 kit 7 perni 901030101100

FS-11 1 perno 901030101800

The FS-11 stand is available in 2 versions, one including the 7 pins full kit or in alternative with 1 pin only chosen by the customer.

I codici sono :

FS-11 kit 7 pins 901030101100

FS-11 1 pin 901030101800



NON montare sulla moto quando il cavalletto è in uso.
DO NOT ride the motorcycle when the stand is in use



HEADSTOCK STANDS



NON montare sulla moto quando il cavalletto è in uso.
DO NOT ride the motorcycle when the stand is in use



FS-11 Sport



Perno Universale Conico
Universal Cone Pin



Perno pivotante in Nylon per Ducati e MV Agusta
Pivoting nylon pin for Ducati and MV Agusta

Codice / Item FS-11/S
Cavalletto Sottocanotto
Headstock Stand

Larghezza / Width	37 cm
Peso / Weight	7.0 kg
Lunghezza / Length	57 cm
Altezza min. Min. Height	65.5cm
Altezza Max. Max Height	81.5cm
Perni Inclusi Pins included	

Codice / Item FS-11/NEW
Cavalletto Sottocanotto
Headstock Stand

Larghezza / Width	37.5 cm
Peso / Weight	11.7 kg
Lunghezza / Length	50 cm
Altezza Min. Min. Height	65 cm
Altezza Max Max Height	80 cm
Perni Inclusi Pins included	



Perno Universale Conico
Universal Cone Pin



Piastra Ducati e MV Agusta
Ducati and MV Agusta plate



FS-11 New

OFFROAD STANDS

PP/E-R

PP/E



PPE cavalletto cross
PPE Offroad stand

Codice / Item	PP/E
Larghezza / Width	PP/E-R
Lunghezza / Length	24 cm
Altezza / Height	24 cm
Portata / Load Cap.	43 cm
	150kg



KS-2012 Offroad
SKS-2012 Motard

Codice / Item KS-2012

Larghezza / Width	21 cm
Lunghezza / Length	28 cm
Altezza Min./Min.Height	31.5 cm
Altezza Max./Max Height	43.3 cm
Portata/ Load Cap.	160 kg

Codice / Item SKS-2012

Larghezza / Width	21 cm
Lunghezza / Length	28 cm
Altezza Min./Min.Height	25.7 cm
Altezza Max./Max Height	37.5 cm
Portata/ Load Cap.	160 kg



NON montare sulla moto quando
il cavalletto è in uso.
DO NOT ride the motorcycle when
the stand is in use



Bike-Lift
www.bikelifteurope.it

ATTENZIONE
PRIMA DI USARE
LEGGERE IL LIBRO
D'ISTRUZIONI
CITATO IN
FOGLIO INFORMATIVO
IN DOTAZIONE

AVVERTENZE
PER IL MONTAGGIO
E L'USO
SICURTÀ
ELETTRICITÀ



**SVILUPPO
OFFICINA
Workshop Build-Up**



Bike-Lift Europe fornisce ai propri clienti un servizio professionale nella realizzazione della propria officina, sia di nuovo allestimento che di riammodernamento.

Quando si decide di aprire un'officina moto, o semplicemente di rinnovare il proprio luogo di lavoro, è necessario avvalersi di un partner che possa garantire un servizio a 360°, affiancando il cliente non solo nella fornitura dei migliori materiali ma anche nella realizzazione e studio del progetto, affinché sia il più funzionale possibile. Un team di esperti della Bike-Lift Europe, dopo un primo sopralluogo dei locali ed un approfondito colloquio con il cliente, in cui verranno fissate le esigenze di tipo logistico e lavorativo (target, volume di lavoro, numero postazioni, tipologia di interventi sui veicoli etc.) dell'officina, svilupperà un progetto finalizzato al miglior allestimento possibile, in termini di efficacia ed efficienza. Il valore aggiunto che Bike-lift Europe offre ai propri clienti è quello di trovare in un unico interlocutore la competenza e professionalità mirate a poter garantire soluzioni idonee alla propria tipologia di lavoro, sfruttando al meglio lo spazio disponibile e garantendo un servizio studiato ad-hoc.

Bike-Lift Europe offers to its customers a professional service about the realization of the workshop, a new one or a refurbishing of an existing one.

When you decide to open a motorcycle workshop or just renovate your workplace, it is important to rely on a partner that can ensure an all-round service and support the client not only by supplying the best materials but also implementing the project. A Bike-Lift Europe team of experts will visit the premises and talk to the customer to pin-point logistic and work requirements (target, volume of work, number of bays, type of interventions on the vehicles etc.) and develop the project in order to obtain the best result possible in terms of effectiveness and efficiency. Bike-Lift Europe's added value is about providing a single interface to the customer that can ensure the best solution to meet all requirements, making use of all the available space and guaranteeing a tailor-made service that stands out for professionalism.

Bike-Lift®
EUROPE





ATTREZZATURA PROFESSIONALE

Professional Tools



Accessori in dotazione / Accessories included

Torretta in Ferro
Torretta moto in Teflon con attacco
Protezione Stallonatore
Griffe Standard
Griffe CKM

Iron Head
Teflon Head for Motorcycles with fitting
Bead Breaker protection
Standard Rim Clamps
CKM Rim Clamps

Potenza / Power
Peso / Weight
Aria / Air
Pot. Motore/Engine Pwr.
Apert.Griffe/Clamp Range
Apertura Max Stallonatore/
Bead breaker max opening
Forza Stallonatore/Bead breaker Pwr.
Diam. Ruota Max./Max Wheel Diam.
Largh. Max Ruota/ Max Wheel width
Velocità rotazione/Rotation Speed
Dimensioni / Dimensions

BIKE-21N

CARATTERISTICHE TECNICHE TECHNICAL DETAILS

Smontagomme semi-automatico per motocicli, scooters quad, go-karts e macchine da giardinaggio. E' ideale per utilizzatori che necessitano di un sistema di stallonatura tradizionale. Il piatto auto-centrante permette di serrare cerchi da 6" a 24".

Le principali caratteristiche sono :

- Braccio orizzontale a ribaltamento laterale e bloccaggio manuale del braccio verticale porta utensile.
- Piatto auto-centrante avente capacità da 6" a 24" grazie a 3 differenti posizioni di bloccaggio facilmente selezionabili senza necessità di utensili.
- Sistema di stallonatura tradizionale dotato di specifica paletta con protezione.
- Torretta di montaggio con inserti in plastica per cerchi in lega.

Semi-automatic tyre changer, designed to mount and demount motorcycle, mopeds, ATV, Quads, Go-karts and turf vehicles. It is conceived for operators looking for a traditional bead breaking system. The self-centering turntable locks rims from 6" to 24" with the standard adapters supplied.

The main features are:

- Proven and reliable semi-automatic swing arm configuration and manual locking system of the vertical working arm.
- Self-centering turntable with capacity from 6" to 24" performing 3 different clamping positions easily selectable without the use of extra tools.
- Traditional bead braking system equipped with a specific rim protection cover.
- Tool head supplied with plastic protection inserts for alloy rims.

Codice / Item
BIKE-21N/230V

Codice / Item
BIKE-21N/380V

230V
174 kg
08-10bar
0.75/1 Kw
6"-24"
310mm
310mm
2500kg
960mm(37")
250mm(10")
6 Rpm
1830x1060x1020mm

380V
174 kg
08-10bar
0.75/1 Kw
6"-24"
310mm
310mm
2500kg
960mm(37")
250mm(10")
6 Rpm
1830x1060x1020mm

BIKE-35N

CARATTERISTICHE TECNICHE TECHNICAL DETAILS



Smontagomme automatico professionale per motocicli, scooters, quad, go-karts e macchine da giardinaggio. E' ideale per utilizzatori che necessitano di un sistema di stallonatura tradizionale. Il piatto auto-centrante permette di serrare cerchi da 6" a 26".

Le principali caratteristiche sono :

- Palo verticale dotato di sistema recupero giochi a boccole coniche.
- Piatto auto-centrante a doppio senso di rotazione dotato di bielle curve per mantenere costante la forza di serraggio al variare del diametro del cerchio.
- Sistema di stallonatura tradizionale dotato di specifica paletta con protezione.
- Torretta di montaggio con inserti in plastica per cerchi in lega.

Automatic professional tyre changer, designed to mount and demount motorcycle, mopeds, ATV, Quads, Go-karts and turf vehicles. It is conceived for operators looking for a traditional bead breaking system. The self-centering turntable locks rims from 6" to 26" with the standard adapters supplied.

The main features are:

- Vertical post equipped with conic bushes to recover clearances which could appear after an intensive use of the machine.
- 2 ways rotation turntable clamping system which employs unique rod geometry to constant and even clamping power throughout all rim diameters.
- Traditional bead braking system equipped with a specific rim protection cover.
- Tool head supplied with plastic protection inserts for alloy rims.

Accessori in dotazione / Accessories included

Torretta in Ferro
Torretta moto in Teflon con attacco
Protezione Stallonatore
Griffe Standard
Griffe CKM

Iron Head
Teflon Head for Motorcycles with fitting
Bead Breaker protection
Standard Rim Clamps
CKM Rim Clamps

Smontagomme Automatico Automatic Tyre Changer

Codice / Item
BIKE-35N/230V

Codice / Item
BIKE-35N/380V

Potenza / Power
Peso / Weight
Aria / Air
Pot. Motore/Engine Pwr.
Apert.Griffe/Clamp Range
Apertura Max Stallonatore/
Bead breaker max opening
Forza Stallonatore/Bead breaker Pwr.
Diam. Ruota Max./Max Wheel Diam.
Largh. Max Ruota/ Max Wheel width
Velocità rotazione/Rotation Speed
Dimensioni / Dimensions

230V	380V
250 kg	250 kg
08-10bar	08-10bar
0.75/1 Kw	0.75/1 Kw
6"-26"	6"-26"
330mm	330mm
330mm	330mm
3000kg	3000kg
1000mm(39")	1000mm(39")
250mm(10")	250mm(10")
6 Rpm	6 Rpm
1720x1100x930mm	1720x1100x930mm

BIKE-SM



Bike-Lift®
EUROPE



Codice / Item BIKE-SM

Smontagomme Manuale Portatile
Manual Portable Tyre Charger.

Peso / Weight 20.0 kg
Diam.Ruota 12" a 21"
Max Wheel Diam. 12" to 21"

Accessori / Accessories

Leva / Premi Tallone / Sapone 1kg
Lever / Bead Breaker / Lubricant 1kg



Codice / Item BL-PSC-A
Colore / Color Arancio/Orange



BL-PSC-B Blu/Blue



BL-PSC-C Cromo/Chrome



BL-PSC-G Grigio/Grey



BL-PSC-N Nero/Black



BL-PSC-O Oro/Gold



BL-PSC-R Rosso/Red



BL-PSC-V Verde/Green



BL-PSC-W Bianco/White

Confezioni da 50 strisce da 45 gr l'una
Package of 50 stripes of 45 gr each

Codice / Item BL-51548



Monta valvole pneumatici
Revolving Nozzle

Codice / Item WR-27



Rimuovi piombi in plastica
Rim weight remover

Codice / Item BL-4980



Smonta valvole pneumatici
Stubby valve core remover

ACCESSORI SMONTAGOMME

TYRE CHANGER
ACCESSORIES

Codice / Item
KA-7023

Protezione cerchioni
Rim protectors



Codice / Item
BL-4330

Leva con protezione
Lever with plastic protection

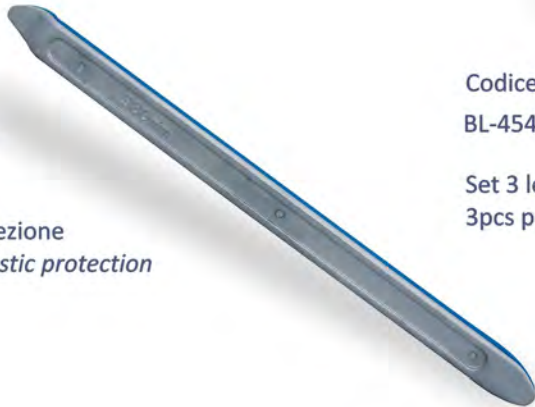

Codice / Item
BL-4540

Set 3 leve professionali in acciaio
3pcs professional tyre iron levers

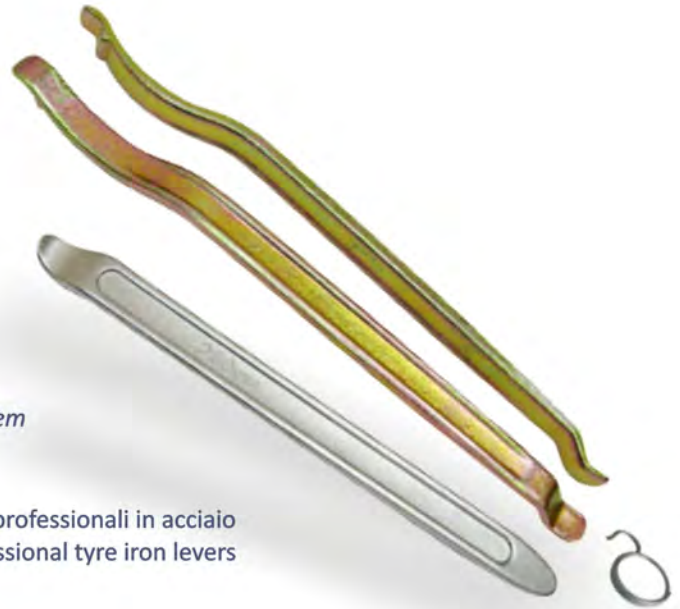

Codice / Item
UCA

Kit n.4 griffe ruote da cross 5"-25"
4pcs off-road tyre clamps 5"-25"



Codice / Item
ATV

Kit n.4 griffe bloccaggio ruote ATV
4pcs ATV tyreslocking clamps



ACCESSORI SMONTAGOMME

TYRE CHANGER
ACCESSORIES



Codice / Item
CKM

Kit 4pz griffe bloccaggio
4pcs rim clamps kit



Codice / Item
GKS

Kit 4pz protezioni in
plastica per griffe
4pcs rim clamps plastic
protections kit



Codice / Item
PPM

Kit 6pz protezioni in
plastica stallonatrice
6pcs bead breaker
plastic protections kit



Codice / Item
KIT GK

Kit 4pz adattatori
bloccaggio ruote kart
4pcs kart wheels
locking adapters kit



Codice / Item
CUP

Corpo utensile in
plastica
Plastic demount
head



Codice / Item
UPA

Utensile in plastica
completo con attacco
rapido.
Plastic demount head
with fast-lock fitting



Codice / Item
TRS

Torretta in acciaio per
ruote scooter da 8"
8" Moped wheels s/steel
demount head

ACCESSORI SMONTAGOMME

TYRE CHANGER ACCESSORIES

Codice / Item

IP1-2K

Set 5pz inserti in plastica
per torretta 2K
5pcs demount head 2K
plastic inserts set



Codice / Item

IP2-2K

Set 5pz inserti in plastica
per torretta 2K
5pcs demount head 2K
plastic inserts set



Codice / Item

MC-98

Torretta in acciaio 13"-23"
13"-23" st. steel demount head



Codice / Item

BL-221618

Utensile in plastica
Plastic demount head



Codice / Item

DHF

Flangia per utensile
BL-221618
BL-221618 demount
head flange



Codice / Item

BL-10604

Pistola di gonfiaggio
con manometro
Inflating gun with
manometer



Codice / Item

BL-42599

Pistola di gonfiaggio con manometro
certificato
Certified inflating gun with manometer



Codice / Item

BL-69924

Manometro regolazione
pressione
Tyre pressure gauge



Codice / Item

BL-TL

1kg lubrificante per mont./
smontaggio pneumatici
1kg mount/demount tyre
lubricant grease



BIKE-62N



*Bilanciatrice Elettronica
Electronic Wheel Balancer*

Codice / Item
BIKE-62N

CARATTERISTICHE TECNICHE TECHNICAL DETAILS



Equilibratrice elettronica con programmi distinti per moto e quad. Presenta la caratteristica esclusiva di poter tarare unicamente la flangia moto senza il relativo gruppo meccanico, quindi con risultati più precisi. Sulla base sono predisposti dei supporti per ruote per poter rendere trasportabile la macchina, rendendola ideale per il servizio mobile. Per agevolare questi tipo di servizio la macchina può essere alimentata anche a 12-24V tramite l'apposito alimentatore fornito con presa per accendisigari auto. La macchina viene fornita con un corredo accessori completo per la messa in opera immediata e senza necessità di ulteriori accessori. Le caratteristiche principali sono :

- Lancio manuale della ruota.
- Acquisizione manuale dei dati geometrici della ruota.
- Freno di stazionamento a pedale.
- Calibrazione gruppo flangia senza il relativo gruppo meccanico.
- 2 programmi di bilanciatura ruote (statico e dinamico).
- Programma divisione pesi.
- Programma pesi nascosti.

Electronic wheel balancer featuring two separate balancing programs for motorcycles and quads. It has the unique feature of calibrating the single motorbike flange without its mechanical group, thus assuring a more accurate results.

The base is provided of dedicated feet to which connect casters and so making the machine movable and ideal for a mobile service. To allow this service the machine can work with 12-24V with the use of a specific cable supply included in the accessories that can be plug into the car lighter socket.

The machine is supplied with a comprehensive set of accessories for its immediate operativity, without the need of extra tools.

The main features are :

- Hand spin of the wheel.*
- Manual acquisition of the geometric wheel data.*
- Mechanical pedal brake.*
- Flange calibration without the motorbike mechanical group.*
- 2 balancing programs (static and dynamic).*
- Split weight program.*
- Hidden weight program.*

Accessori in dotazione / Accessories included



Potenza / Power	230V
Peso / Weight	80 kg
Dimensioni / Dimensions	125x42x105 cm
Peso Max Ruota/Max Wheel weight	70 kg
Diam. Max ruota/Max diam. wheel	112 cm
Larghezza cerchio/Rim width	59 cm
Diam. Cerchio Impostabile / Settable Rim Diameter	8" - 35"
RPM	<100 rpm
Precisione Squilibrio/Balancing precision	1 gr
Velocità di equilibratura/Balancing Speed	5.5 sec.



Kit Bilanciamento Optional / Optional Balancing Kit

Flangia/Mandrino a innesto Cilindrico D.40	Carrier/Cylindrical insert chuck D. 40
Dado Esagonale	Hexagonal Nut
Albero moto D. 14mm	Motorbike shaft D. 14mm
Kit di fissaggio	Fixing Kit
Boccole 15mm-17mm-20mm	Centering sleeves 15mm-17mm-20mm
Cono centraggio standard	Standard centering cone
Cono centraggio 16-45mm	Centering cone 16-45mm
Bloccaggio rapido per perno D.14mm	Quick-lock for D. 14mm shaft
Dado Zigrinato	Knuled Nut
Tubo distanziatore 15mm	Spacing Sleeve 15mm
Boccola centraggio Piaggio-Vespa	Piaggio-Vespa centering sleeve
Tassello di spinta per BMW	BMW pressure piece
Prolunga tastatore interno	Prolonge for internal tester
Chiave a forchetta	Open-ended spanner

BENCH MOTO-MEC

Equilibratrice Elettronica da Banco Codice / Item
Workbench Electronic Wheel Balancer BIKE-MOTO-MEC

NEW



Staffe per fissaggio sul bordo del piano di lavoro
Fixing brackets for the tabletop edge

Le dimensioni estremamente ridotte la rendono la soluzione ideale per chi ha esigenze di spazio ma non solo. E' infatti la giusta scelta per l'uso in pista o per il servizio mobile, dove sia necessario spostare ed utilizzare l'equilibratrice in posti diversi.

The BENCH MOTO MEC is the ideal solution for working areas with reduced space, but not only. It is also the best choice for racetracks or for a mobile service, wherever may be necessary to use the wheel balancer in different places.

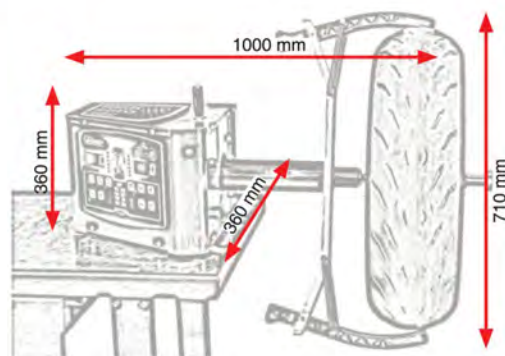



BENCH MOTO-MEC



ACCESSORI IN DOTAZIONE
STANDARD ACCESSORIES

Alimentazione / Power	220V / 12V
Peso / Weight	40 kg
Dimensioni / Dimensions	36x36 cm
Peso Max Ruota/Max Wheel weight	50 kg
Diam. Max ruota/Max diam. wheel	89 cm
Larghezza cerchio/Rim width	50 cm
Diam. Cerchio Impostabile / Settable Rim Diameter	8" - 35"
RPM	80 rpm
Precisione Squilibrio/Balancing precision	1 gr
Velocità di equilibratura/Balancing Speed	5.5 sec.

CARATTERISTICHE TECNICHE TECHNICAL DETAILS

- Lancio manuale della ruota.
Hand spin of the wheel.
- Acquisizione manuale dati geometrici della ruota.
Manual acquisition of the wheel data.
- Freno manuale.
Mechanical hand brake.
- Programma divisione dei pesi.
Split weight program.
- Programma pesi nascosti.
Hidden weight program.
- Programmi di equilibratura STATICO e DINAMICO.
STATIC and DYNAMIC balancing programs for motorcycle wheels.
- Calibrazione del gruppo flangia moto. Presenta la caratteristica esclusiva di poter tarare unicamente la flangia moto senza il relativo gruppo meccanico con risultati più precisi.
Motorbike flange calibration. The machine offers the unique feature of calibrating the single motorbike flange without its mechanical group and so assuring more accurate results.



**ACCESSORI
BILANCIATRICE
ELECTRONIC BALANCER
ACCESSORIES**

Codice / Item
A-141



Adattatore per BMW con
perno D. 14mm
Adapter for BMW for D. 14mm pin

Codice / Item
A-191



Adattatore Harley Davidson
per perno D. 19mm
*Adapter for Harley Davidson
for D. 19mm pin*

Codice / Item
A-192



Adattatore Suzuki GSXR
per perno D. 19mm
*Adapter Suzuki GSXR
for D. 19mm pin*

Codice / Item
A-193



Adattatore per Aprilia-BMW-
Yamaha per perno D. 19mm
*Adapter for Aprilia-BMW
Yamaha for D. 19mm pin*

Codice / Item
A-194



Adattatore Harley-Davidson
V-Road per perno D. 19mm
*Adapter for Harley-Davidson
V-Road for D. 19mm pin*

Codice / Item
A-195



Centraggio 25mm per perno
D. 19mm
*25mm centering adapter
for D. 19mm pin*

Codice / Item
A-196

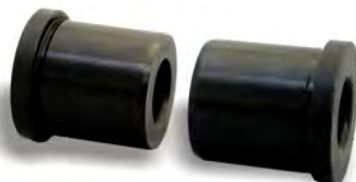

Centraggio 35mm per
perno D. 19mm
*35mm centering adapter
for D. 19mm pin*

Codice / Item
A-197



Adattatore Honda
650-GL1800 per
perno D. 19mm
*Honda 650-GL 1800
for D. 19mm pin*

Codice / Item
A-198



Adattatore MV-Agusta
perno D. 19mm
*Adapter MV-Agusta
for D. 19mm pin*

Codice / Item
A-199



Adattatore Ducati-Triumph
per perno D. 19mm
*Ducati-Triumph adapter
for D. 19mm pin*

Codice / Item
BR-14
BR-19



Bloccaggio rapido per
perno da 14mm o 19mm
*Quick lock for 14mm or
19mm pin*

Codice / Item
PB14-B62
PB19-B62

Perno D. 14mm / Pin D. 14mm
Perno D. 19mm / Pin D. 19mm



BIKE-35N

PATENT DESIGN N° 00191653-0002

Bike-Lift
EUROPE

**Bilanciatrice Statica
Static Wheel Balancer**

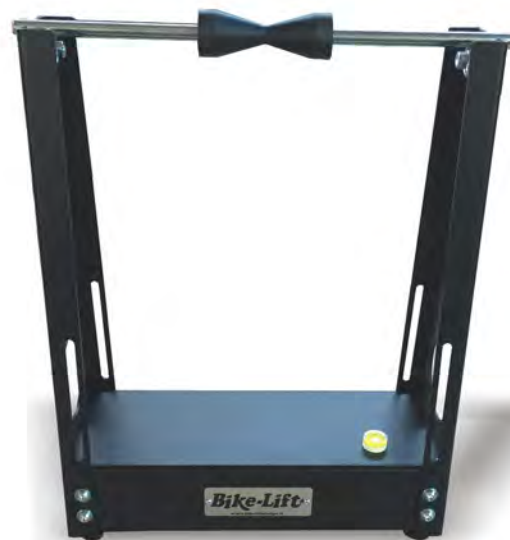

*Bilanciatrice Statica
Static Wheel Balancer*

Codice / Item
B-35N

Bilanciatrice statica utilizzabile su tutte le ruote fino a 21". Progettata per ottimizzare la logistica delle spedizioni, per facilitare il montaggio e per migliorare l'estetica ed il design, nonché completarne la funzionalità con nuovi accessori.

Veloce da montare, meno ingombrante e più leggera, la B-35N offre tutte le funzionalità necessarie nell'ambito della bilanciatura. Fornita con asta in acciaio da 12mm e coppia di coni con diametro massimo da 40mm. Fornita in scatola di montaggio.

Static balancer applicable on all kind of wheels till 21". Designed to obtain a better logistic size to have an easier assembling procedure, to achieve a better design and complete the functionality with new accessories.

Quick to assemble, reduced dimensions and lighter in weight, it offers all the necessary functionalities when working on wheel balancing. Supplied with a 12mm stainless steel shaft bar and a pair of cones with maximum diameter of 40mm. Supplied in assembling kit box.



Codice / Item
B-SR
KIT CENTRAGGIO PER
CERCHI A RAGGI

*CENTERING KIT FOR
SPOKED RIMS*



Bilanciatrice Statica Static Wheel Balancer



*Bilanciatrice Statica
Static Wheel Balancer*

Codice / Item
BL-124-00



Bilanciatrice statica completa di tutti gli accessori necessari al bilanciamento e centraggio dei cerchi della maggioranza dei modelli moto e scooters. E' fornita di asta in acciaio di 12mm di diametro con coni per ruote da 10" a 21", ruotante su cuscinetti a sfera in acciaio. Perni regolabili a punta conica da 16mm a 30mm ed asta per il centraggio dei cerchi a raggi con check-point a 90°. Fornita anche di livella a bolla incorporata. Fornita in scatola di montaggio.

Static balancer supplied with all necessary tools for the balancing and centering of the rims of almost all models of motorcycles and mopeds. It is supplied with a steel shaft bar of 12mm diameter with cones for wheels from 10" up to 21", spinning on stainless steel ball bearings, tapered cone axle stoppers from 16 up to 30mm and rim centering bar at 90°. It is equipped with a level-eye. Supplied in assembling kit box.



ADATTATORI BILANCIATRICE

WHEEL BALANCER ADAPTERS



Codice / Item
B-AU

Kit di 3 coni componibili e due dadi di fermo, che permette di lavorare su praticamente tutti i cerchi moto e scooter.
3 cones+2 nuts universal kit that allows to operate on almost all models of motorcycle and moped rims.



Codice / Item
B-A00

Adattatore standard diam. 12mm
Standard adapter diam. 12mm



Codice / Item
B-A01

Adattatore monobraccio
Single sided swing-arm adapter



Codice / Item
B-A02

Adattatore BMW
BMW adapter



Codice / Item
B-A03

Adattatore maxi scooters diam. 10mm
Maxi scooters adapter diam. 10mm



Codice / Item
B-A04

Adattatore Piaggio X9
Piaggio X9 adapter



Codice / Item
B-A05

Adattatore BMW dal 2006 in poi.
BMW adapter for models from 2006 onwards



Codice / Item
BL-124-01

Adattatore BMW 1200.
BMW 1200 adapter.

ES-06



CARATTERISTICHE TECNICHE TECHNICAL DETAILS



DIMENSIONI / DIMENSIONS
PESO / WEIGHT

50x70x120 cm
25 kg

Codice / Item
ES-06

SUPPORTO MOTORE CON RUOTE
ENGINE STAND WITH CASTERS



ACCESSORI OPTIONAL
OPTIONAL ACCESSORIES

Codice / Item
ES-06/DUC

Codice / Item
ES-06/AS



Flangia per motori DUCATI
DUCATI engines flange



Flangia per motori maxi scooters
Maxi scooters flange

SA-07



Codice / Item SA-07
SMONTA AMMORTIZZATORI
SHOCK ABSORBER DISASSEMBLER

Peso / Weight 20 kg
Dimensioni/Dimensions 25X25X100 cm



Adattatori in Dotazione Standard
Standard included adapters



- Diametro/Diameter 45 mm
- Diametro/Diameter 47 mm
- Diametro/Diameter 50 mm
- Diametro/Diameter 53 mm
- Diametro/Diameter 56 mm
- Diametro/Diameter 59 mm
- Diametro/Diameter 62 mm
- Diametro/Diameter 66 mm
- Diametro/Diameter 68 mm
- Diametro/Diameter 71 mm
- Diametro/Diameter 75 mm
- Diametro/Diameter 77 mm
- Diametro/Diameter 80 mm
- Diametro/Diameter 83 mm
- Diametro/Diameter 87 mm

PSB-20



CARATTERISTICHE TECNICHE TECHNICAL DETAILS

PRESSA IDRAULICA 20 TON
20 TONNE HYDRAULIC PRESS

DIMENSIONI / DIMENSIONS	170x85 cm
PESO / WEIGHT	150 kg
CORSA CILINDRO / STROKE	26 CM
DIMENS. INT. / INT. DIM.	50 CM

Codice / Item PSB-20



VASCA LAVAPEZZI 138L STATIONARY PARTS WASHER



Codice / Item 5904

Alimentazione/Voltage	230V
Potenza/Power	60 W
Press. Max/Max. Pressure	0.5 bar
RPM	2800
Protezione/Protection	IP 54
Cap.vasca totale/Basin total cap.	138 L
Cap.utile /Working capacity	62 L
Dimensioni/Dimensions	50x70x112 cm
Peso/Weight	53 kg

VASCA LAVAPEZZI MOBILE 60L MOVABLE PARTS WASHER 60L



Codice / Item 5953

Aliment./Air Supply	4 bar
Press. Max/Max. Pressure	4 bar
Cap.vasca tot./Basin cap.	60 L
Dimensioni/Dimensions	56x70x81cm
Peso/Weight	36 kg



ATTREZZATURE EQUIPMENT

Bike-Lift®
EUROPE



AM40/315

AM80/8
AM85/8



Codice / Item AM80/8
Cavo aria da 10mt con tubo in PU
Air Hose 10mt with PU tube

Codice / Item AM85/8
Cavo aria da 15mt con tubo in PU
Air Hose 15mt with PU tube

Codice / Item AM40/315
Cavo elettrico D.2mm 3Gx1.5mm con
protezione anti-riscaldamento.
Cavo interno 15mt + 1mt esterno
Electric cable D. 2mm 3Gx1.5mm with
over-heat protection.
Int. cable 15mt +1 mt external



Contenitore olio Usato
Waste Oil tank



Contenitore Batterie Usate
Waste Accumulator Tank

Codice / Item EXOIL-300
Codice / Item EXOIL-500

Capacità/Capacity 300 L / 500 L
Altezza/Height 108cm/124cm
Diam./Diam. 82cm / 96cm



Codice / Item BT-300
Capacità/Capacity 297L-300kg
Dim. Int./Int. Dim. 94x64x50cm
Dimens./Dimensions 100x70x65cm

Recuperatore Olio
Oil Drainer Recover



Codice / Item 3183

Cap.Vasca/Basin Cap. 10 L
Cap. Recup./Recovery Cap. 65 L
Press./Pressure 0.5 bar
Alt. Max/Max Height 140 cm
Peso/Weight 30 kg
Dimensioni/Dimensions 45x57x120cm



Base di Contenimento
Spill containment base



Codice / Item 8524/SE
Peso / Weight 55 kg
Dimens./Dimensions 92x83x34cm



Codice / Item 8532/E
Peso/Weight 35 kg
Dimens./Dimensions 135x83x34 cm

Base di contenimento per 2 fusti
2 drums spill containment base

Codice / Item ECO-T10
Capacità/Capacity 10 L
Dimens./Dimensions 57X32X13cm



Tanica Oilo Esausto 10 L
10 L Waste Oil Tank



Tanica Oilo Esausto 12 L
12 L Waste Oil Tank

Codice / Item ECO-T12
Capacità/Capacity 12 L
Dimens./Dimensions 57X37X13.5cm



Vasca Olio Esausto per Scooter
Moped Waste oil Pan



Codice / Item BL-04265
Capacità/Capacity 3 L
Peso / Weight 1.5 kg



RAMP-4000

Codice / Item	RAMP-4000
Lunghezza/Length	240 cm
Larghezza/Width	28 cm
Altezza bordo/ Edge Height	50 mm
Peso/Weight	7 kg
Portata/Capacity	Max 340 kg

DISPONIBILE ANCHE IN VERSIONE
COLORATA DA ABBINARE AL COLORE
DEL PROPRIO VEICOLO.

COLORED VERSION ON DEMAND
TO MATCH THE COLOR OF YOUR
OWN VEHICLE





Confezione da 2 pz
2 pcs rack pack

Codice / Item TD-1B
Lunghezza/Length 180 cm
Tenuta / Max Strength 500 kg



Confezione da 2 pz
2 pcs rack pack



R-1B



Codice / Item R-1B
Lunghezza/Length 360 cm
Tenuta / Max Strength 500 kg

MORSE PER FURGONI E TRAILER

Bike-Lift®
EUROPE

**WHEEL CLAMPS FOR
VAN & TRAILERS**

W-36F



Codice / Item

W-36 F

Lunghezza / Length

69 cm

Altezza / Height

43 cm

Peso / Weight

14 kg

Azionamento / Action

Automatic

W-38C



Codice / Item

W-38 C

Lunghezza / Length

67 cm

Altezza / Height

43 cm

Peso / Weight

8 kg

Azionamento / Action

Automatic

W-42



Codice / Item

Max Ruota/Max Wheel

21"

Min. Ruota/Min. Wheel

12"

Dimensioni/Dimensions

36x61x40.5 cm

Peso / Weight

12 kg

Azionamento/Action

Automatic

W-28F



Codice / Item

W-28 F

Apertura Max/Max Opening Range

143 mm

Apertura Min./Min. Opening Range

51 mm

Peso / Weight

10 kg

Azionamento/Action

Automatic

W-29EB



Codice / Item

W-29 EB

Apertura Max/Max Opening Range

143 mm

Apertura Min./Min. Opening Range

51 mm

Peso / Weight

10 kg

Azionamento/Action

Automatic



Regolabile
Fully Adjustable



Per moto da Cross
Dirt Bike only



PIZO
RACING

Kawasaki

Kawasaki

Bike-Lift

Bike-Lift

PIZO

PIZO
FACTORY



Codice / Item

BL-1642

Multichiave per asse ruote con attacco 3/8"
H17-H19-H22-H24
3/8" Spindle tool



Codice / Item

BL-1622

Multichiave in alluminio per asse ruote con
attacco 3/8"
H17-H19-H22-H24
3/8" Aluminium Spindle tool



Codice / Item

24955

Chiave a bussola poligonale per ruota post. Ducati
3/4" 12pts flank socket for Ducati rear wheel



Codice / Item

BL-1630

Chiave a settore regolabile 25-70mm
25-70mm adjustable hook wrench

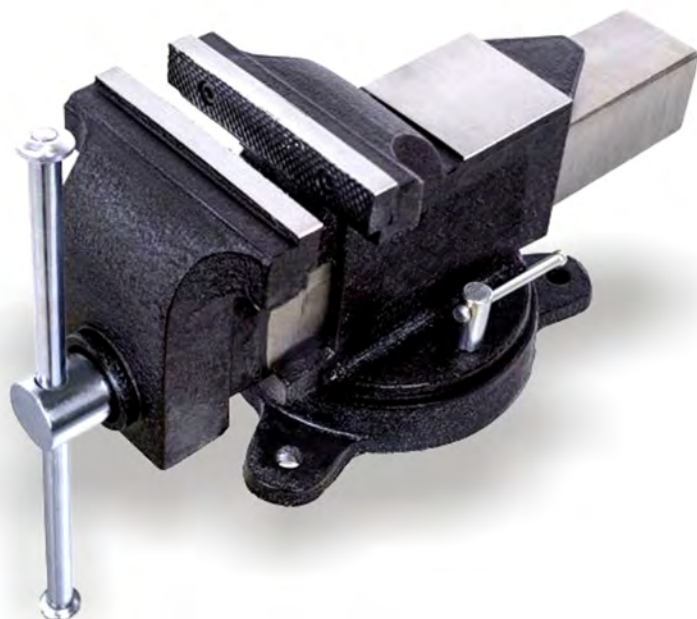

Codice / Item

BL-KRT

Morsa girevole professionale 125mm
Professional vice with swivel base 125mm



Codice / Item

BL-14180

Protezioni magnetiche per morsa da banco
Magnetic soft jaws for bench vice



Codice / Item

BL-45856

Kit estrattori viti spezzate -
3-6/6-8/8-11/11-14/14-18mm
5pcs broken screw extractor set



Codice / Item
BL-35384

Vaschetta magnetica tonda D. 15 cm
Magnetic round tray D. 15 cm



Codice / Item
BL-56332

Vaschetta magnetica rettangolare
24x14 cm
Rectangular magnetic tray 24x14 cm



Codice / Item
BL-72805

Vaschetta magnetica rettangolare 36x16 cm
Rectangular magnetic tray 36x16 cm



Codice / Item
BL-31317

Bacinella ni rete di acciaio per vasca
lava pezzi D. 27 cm
Stainless steel mesh parts bowl D. 27 cm



Codice / Item
BL-4030 (0.6mm) BL-4035 (0.8mm)
Filo inossidabile in bobina da 450 gr.
Lock wire spools of 450 grs.



Codice / Item
BL-4020
Pinza torcifilo acciaio 9"
9" lock wire twisting plier



Codice / Item
088-021
Uncino per trazionamento molle
Spring hook tool



Codice / Item
BL-30826
Utensile separazione pistoncini freni
Disc brake adjuster



Codice / Item
BL-0320

Utensile rimozione cuscinetti sterzo 26-39 mm
Head cup for steering bearings 23-39mm / 1,1-32"/1.17-32"



Codice / Item
BL-0330

Utensile rimozione cuscinetti sterzo
mm
*Head cup for steering bearings 39-57mm
1.17-32" / 2.1-1/4"*



Codice / Item
BL-3815

Strumento misurazione livello olio forcelle
Fork oil level measuring instrument



Codice / Item
BL-0310

Utensile montaggio cuscinetti radiali
Race setting tool set

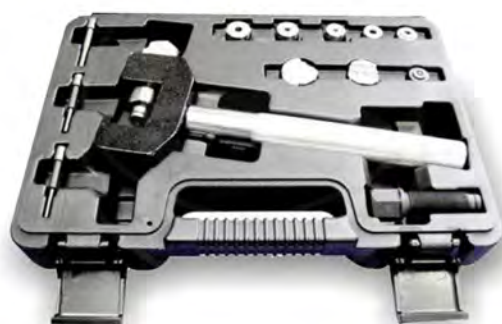

Codice / Item
J-6

Kit smagliatura e rivettatura catena 415>630
Heavy duty chain tool for chains 415>630



Codice / Item
BL-0340

Utensile installazione cuscinetti sterzo 3x42
1x46 1x38 1x36 e 1x32
*Steering bearings installation
tool set*



Codice / Item
BL-3650

Kit installazione guarnizioni forcella mm: 35/36-39-41-43-45-
46/47-48-49/50-54
Fork gasket installation set.

Codice / Item
BL-3620

Morsa universale portatile
Universal portable clamp vice





Codice / Item
BL-2768

Estrattore per volano M14x1.5R/M16x1.5R/M18x1.5
M24x1.5R/M10x1.25R/M27x1.0L
Flywheel puller



Codice / Item
BL-1370

Spazzola pulisci catena
Motorcycle chain brush



Codice / Item
BL-2210

Blocca volano e pulegge
Flywheel holder



ATTREZZATURE EQUIPMENT



Codice / Item
BL-7226152

Kit universale smagliatura/rivettatura catena
Universal heavy duty chain tool kit



Codice / Item
BL-7224744

Kit 11pcs chiave di bloccaggio universale
11pcs kit universal holder



Codice / Item
BL-7220544

Attrezzo regolazione valvole
Tappet adjustment driver set

Codice / Item
BL-6210

Giraviti angolare per carburatore
Angle driver for carburetor

ATTREZZATURE EQUIPMENT



Codice / Item

BL-6141691

Set 30 pz chiavi per filtri olio da D.65>108mm
30pcs set oil filter wrenches



Codice / Item

BL-5925

Disco graduato fasatura motori Ducati
Timing degree gauge for Ducati engines



Codice / Item

BL-19613

Spessimetro combinato 0.03-1.00mm
0.001-0.040 inches feeler gauge dual reading

21706 M5x0.8
21708 M6x1.0
21709 M8x1.25
21710 M10x1.5
21711 M12x1.75



Codice / Item

BL-217...

Set filetti metrici di ricambio (12pz)
Metric thread insert refill set (12pcs)



Codice / Item

BL-0430

Set estrattori cuscinetti interni
motore. MM 8-10-12-15-17-20-25-30
Engine bearing puller set



Codice / Item

BL-56379

Assortimento anelli elastici(seeger) 285pz
Circlip assortment 285pcs (int./ext.)



Codice / Item

BL-7222912

Kit montaggio cuscinetti
mm 40-45-50-59-63-65
Bearing race and seal driver set



Codice / Item

BL-63941

Assort. anelli elastici(seeger) est. 300pz
Circlip assortment 300pcs (ext.)



Codice / Item
BL-79205

Set metrico maschi e filiere 75 pz
Combination tap and die set 75 pcs



Codice / Item
BL-56345

Assortimento o-ring metrici 419 pz
3.0mm x 1.5mm > 50mm x 3.5mm
O-rings assortment 419 pcs



5xHSS punte trapano / 5xHSS maschi rinnova filetti / 5x strumenti rimozione del trascinatore / impugnatura bobinatrice intercambiabile / 5x 1/4" femmina esagonale per giravite magnetica / 2mm chiave esagonale / 60 pz filetti vari
5xHSS twist drills / 5xHSS Second taps / 5x tang breaking tool / interchangeable insert winder handle / 5x 1/4" hex. for magnetic screw insert drivers / 2mm hex key / 60 pcs various threads

Codice / Item
BL-21690

Kit riparazione filetti
Thread repair and workshop kit



Codice / Item
BL-7224777

Serbatoio ausiliario per motori a iniezione
3,6 L
Auxiliary fuel tank for injection engines



Codice / Item
BL-7223530

Attrezzo spurgo olio freni professionale.
Professional brake bleeder set.



Codice / Item
BL-7223068

Serbatoio ausiliario benzina Lt 1
Auxiliary fuel bottle 1 Lt



BL-43963 1 Lt

BL-43964 3 Lt

BL-43965 5 Lt

Codice / Item

BL-4396..

Caraffe con tubo flessibile con scala metrica e US
Flexible spout jug with metric and US graduation



Codice / Item

BL-43853

Set 4 imbuto D. 50/75/100/120 mm
Plastic funnels set 4 pcs



Codice / Item

BL-56141

Imbuto PVC con tubo flessibile D. 110 mm
Diam. 110mm PVC flexible funnel



Codice / Item

BL-45458

Contafiletto a 20 lame
20 blades metric screw pitch gauge



Codice / Item

BL-52427

Calibro digitale doppia misurazione
S.Steel digital caliper dual reading



Codice / Item

BL-11954

Specchietto flessibile per ispezione
Flexible inspection mirror



Codice / Item

BL-499...

Tanica in acciaio a norma per carburante.
Fuel tankers.

BL-49949 20L

BL-49952 10L

BL-49957 5L



Codice / Item

BL-56375

Assortimento coppiglie 555 pz
Split pin assortment 555 pcs

По вопросам продаж и поддержки обращайтесь:

Алматы (7273)495-231	Казань (843)206-01-48	Новокузнецк (3843)20-46-81	Смоленск (4812)29-41-54
Архангельск (8182)63-90-72	Калининград (4012)72-03-81	Новосибирск (383)227-86-73	Сочи (862)225-72-31
Астрахань (8512)99-46-04	Калуга (4842)92-23-67	Омск (3812)21-46-40	Ставрополь (8652)20-65-13
Барнаул (3852)73-04-60	Кемерово (3842)65-04-62	Орел (4862)44-53-42	Сургут (3462)77-98-35
Белгород (4722)40-23-64	Киров (8332)68-02-04	Оренбург (3532)37-68-04	Тверь (4822)63-31-35
Брянск (4832)59-03-52	Краснодар (861)203-40-90	Пенза (8412)22-31-16	Томск (3822)98-41-53
Владивосток (423)249-28-31	Красноярск (391)204-63-61	Пермь (342)205-81-47	Тула (4872)74-02-29
Волгоград (844)278-03-48	Курск (4712)77-13-04	Ростов-на-Дону (863)308-18-15	Тюмень (3452)66-21-18
Вологда (8172)26-41-59	Липецк (4742)52-20-81	Рязань (4912)46-61-64	Ульяновск (8422)24-23-59
Воронеж (473)204-51-73	Магнитогорск (3519)55-03-13	Самара (846)206-03-16	Уфа (347)229-48-12
Екатеринбург (343)384-55-89	Москва (495)268-04-70	Санкт-Петербург (812)309-46-40	Хабаровск (4212)92-98-04
Иваново (4932)77-34-06	Мурманск (8152)59-64-93	Саратов (845)249-38-78	Челябинск (351)202-03-61
Ижевск (3412)26-03-58	Набережные Челны (8552)20-53-41	Севастополь (8692)22-31-93	Череповец (8202)49-02-64
Иркутск (395)279-98-46	Нижний Новгород (831)429-08-12	Симферополь (3652)67-13-56	Ярославль (4852)69-52-93
Россия (495)268-04-70	Киргизия (996)312-96-26-47	Казахстан (7172)727-132	